



**Delco Remy**

**PRODUCT INFORMATION**

**1G-287**

**1/98**

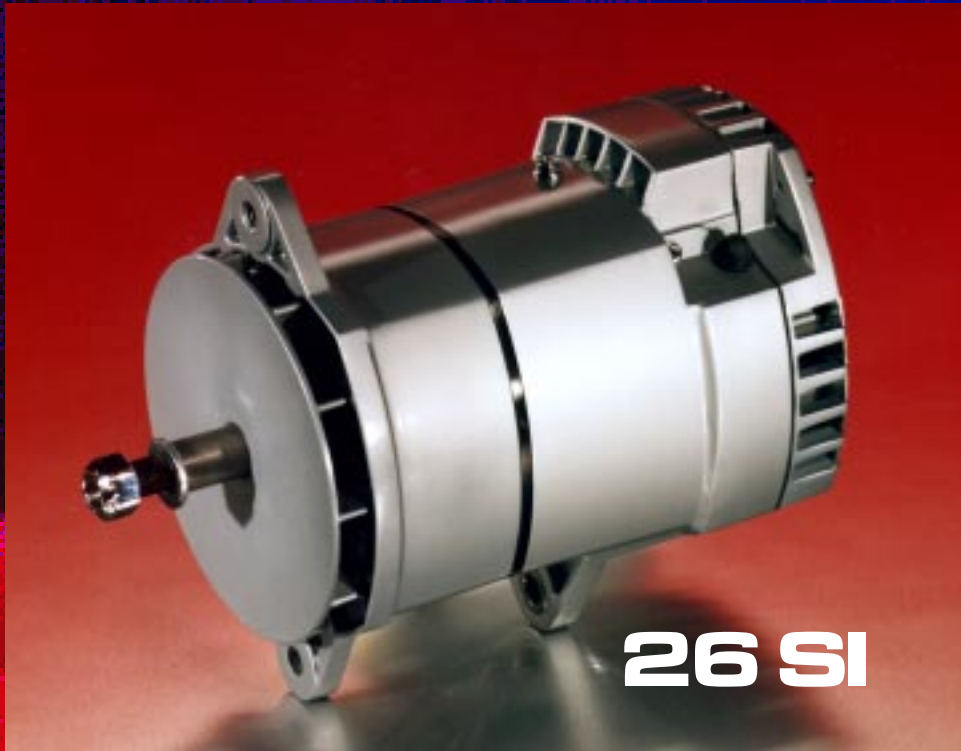

**26 SI**

**HEAVY DUTY  
BRUSHLESS ALTERNATOR  
SERVICE MANUAL**

## FEATURES

### SPECIFICATIONS:

#### MAXIMUM SPEED:

Continuous: 10,000 rpm

Intermittent: 12,000 rpm

#### AMBIENT TEMPERATURE LIMITS:

-40°C to +85°C

(-40°F to + 185°F)

#### TRANSIENT VOLTAGE LIMITS:

100V - 300 ms (12-volt)

250V - 300 ms (24-volt)

**POLARITY:** Negative Ground

#### ROTATION:

Clockwise or Counterclockwise

**WEIGHT:** 27.6 lbs (12.5 kg)

**MOUNTING SPAN:** SAE Standard J180

#### Built-In Voltage Regulator

Solid-State Integrated Circuit

Flat Temperature-Compensated

Low Parasitic Draw

Low Turn-On Speed

Improved RFI Suppression

Load Dump Protection

#### Brushless Construction

Stationary Field Coil

No Brushes or Slip Rings

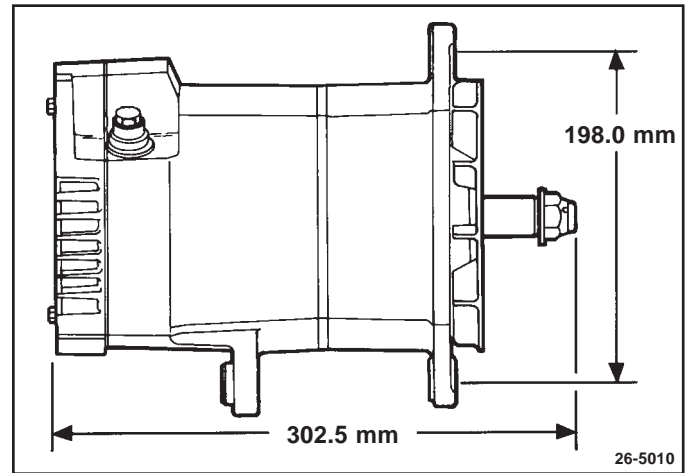

#### “Inside-Cooled” System

Baffled Air Inlet

Sealed Live Parts

Prevents entry of large or foreign material

#### Corrosion Protection

Sealed Rectifier-End Assembly

Brass Output Terminal Hardware

#### Applications

Line-Haul Diesel Trucks

Large Commercial Diesel Engines

Harsh Environments

Heavy Belt Loads and Vibrations

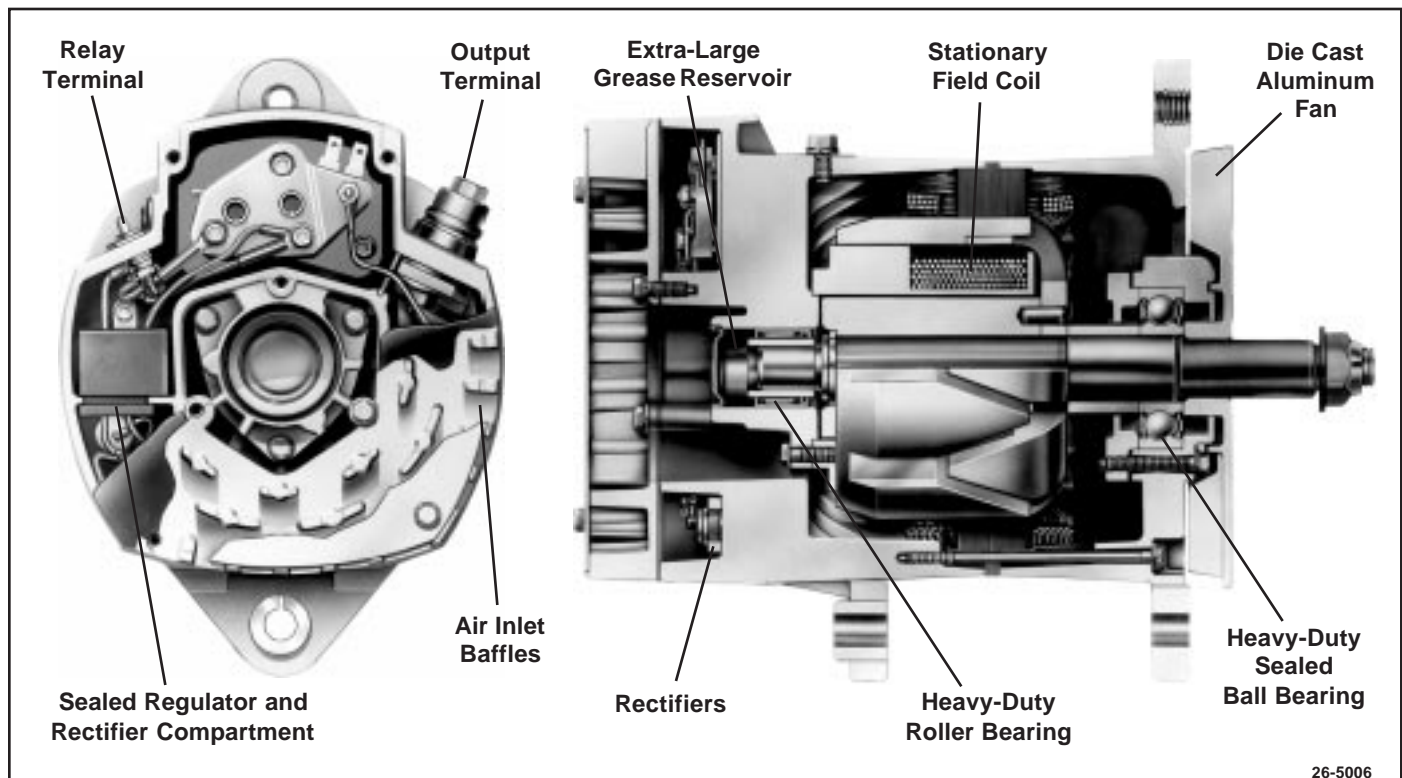

# PRODUCT INFORMATION AND SERVICE MANUAL

## 26-SI HEAVY DUTY BRUSHLESS ALTERNATOR

### CONTENTS

<p>Introduction ..... 1</p> <p>Features ..... 2</p> <p>Operating Principles ..... 3</p> <p>Troubleshooting ..... 3</p> <p style="padding-left: 20px;">A. All Charging Systems ..... 4</p> <p style="padding-left: 20px;">B. Systems with Indicator Light ..... 4</p> <p style="padding-left: 20px;">C. Systems without Indicator Light ..... 5</p> <p style="padding-left: 20px;">D. R Terminal Accessory Problems ..... 5</p> <p style="padding-left: 20px;">E. No Output ..... 5</p> <p style="padding-left: 20px;">F. Rated Output Check ..... 6</p>	<p>Alternator Unit Repair ..... 7</p> <p style="padding-left: 20px;">Disassembly and Bench Checks ..... 7</p> <p style="padding-left: 20px;">Final Disassembly ..... 11</p> <p>Alternator Assembly ..... 12</p> <p style="padding-left: 20px;">DE Frame and Rotor ..... 13</p> <p style="padding-left: 20px;">Rectifier End Housing and Components ..... 13</p> <p style="padding-left: 20px;">Final Alternator Assembly ..... 16</p> <p style="padding-left: 20px;">Alternator Bench Test ..... 19</p> <p>Alternator Mounting ..... 21</p> <p>Service Parts ..... 25</p> <p>Alternator Specifications ..... 26</p>
---	---

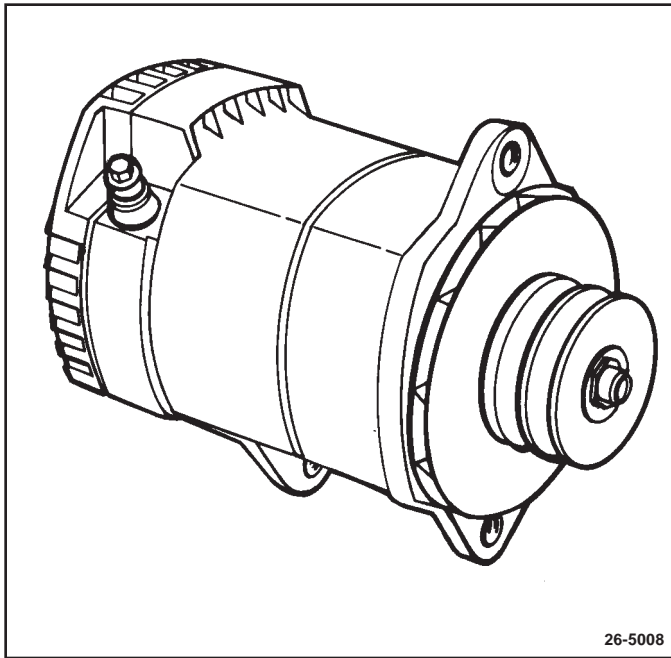

**Figure 1. 26-SI Alternator**

### INTRODUCTION

The 26-SI series alternator is a brushless, heavy-duty integral charging system with built-in diode rectifier and voltage regulator, producing DC current for battery electrical systems. The 26-SI series is designed for use on large and mid-range diesel and gasoline engines in over-the-road service, as well as for off-road, agricultural, and construction equipment.

The 26-SI alternator may be operated in either clockwise or counterclockwise directions (external fan may require changing to reverse rotation) at continuous speeds of up to 10,000 alternator rpm. Intermittent speeds of up to 12,000

alternator rpm are also acceptable. The ambient temperature range for proper operation is -34°C to +85°C (-30°F to +185°F).

The solid state, integrated circuit voltage regulator built into the 26-SI alternator limits system voltage by switching the ground circuit for the rotor field on and off. When the ground circuit is on, field current passes from a diode trio through the stationary field coil. Nominal regulated voltages of 13.8, 14.0, and 14.2 volts are available for 12 volt systems, and 27.5 volts for 24-volt systems.

For 12-volt systems, an output rating of 85 amperes is standard. For 24-volt systems, output ratings of 50 or 75 amperes are available. Refer to Figure 2 for graphs of typical outputs over a range of alternator speeds. For output ratings of specific 26-SI models refer to the Specifications section of this manual.

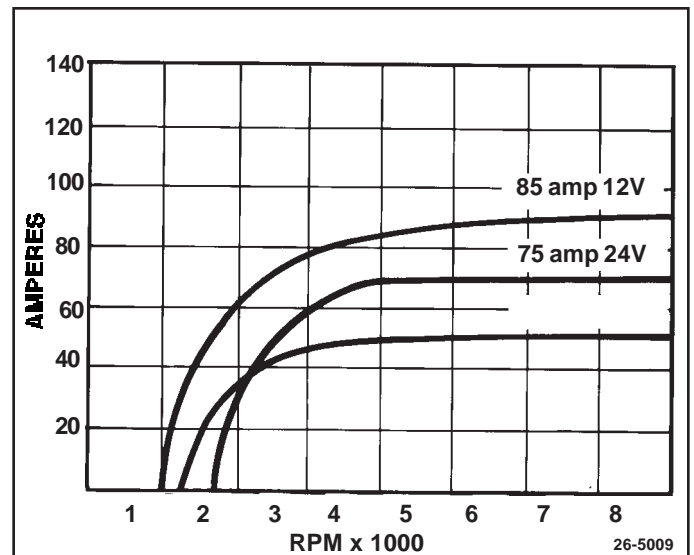

**Figure 2. Typical Output vs. Alternator RPM**

## FEATURES

The 26-SI alternator is designed for a “one-wire” charging system configuration. “One-wire” refers to the minimum number of lead wire connections necessary at the alternator for operation and requires only that the alternator output terminal be connected to the battery insulated (positive for a negative-ground system) terminal and that a ground path be provided between the alternator housing and the battery ground terminal. (See Figure 3)

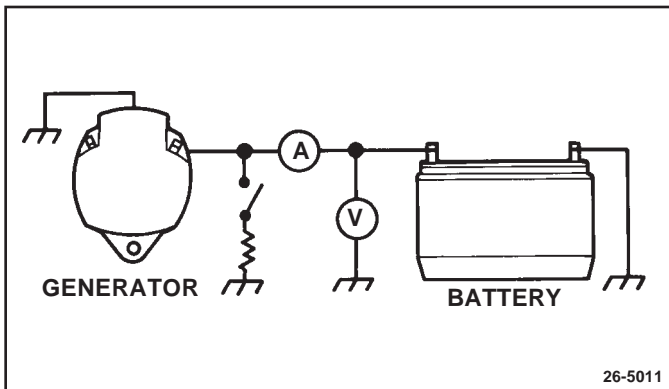

**Figure 3. Basic One-Wire System**

Some applications use an “I” terminal circuit to power an indicator light and/or to lower the engine speed (RPM) at which the alternator will turn on. Typical system wiring using this type of circuit is shown in Figure 4. This is commonly referred to as a “one-wire system with I terminal” or as a “two-wire system.”

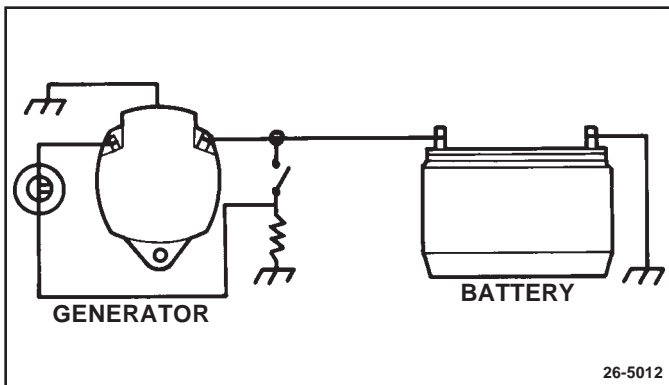

**Figure 4. One-Wire System with I Terminal**

External connections to the 26-SI alternator are made to terminals shown in Figure 5. The standard output terminal is a “female” type with insulated connecting bolt and charge lead cable with a special connector. When installed, the electrical connection is sealed from moisture and there are no exposed parts with battery voltage. The connector bolt head is normally stamped “No Volts” to indicate the insulated type.

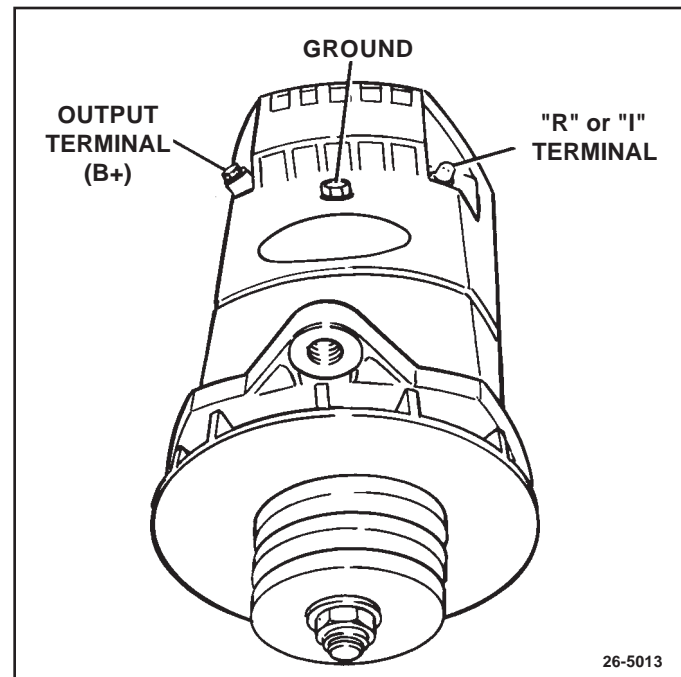

**Figure 5. 26-SI Electrical Terminals**

Some 26-SI models use a 1/4" threaded stud type of output terminal. With this type of terminal, the exposed metal parts are not insulated and will have battery voltage when connected to the battery.

Optional connections to the 26-SI series include either an “R” (relay) or “I” (indicator light) terminal, and a ground lead connection to the alternator’s rectifier end housing.

An “R” or relay terminal is located on the side of the alternator opposite from the output terminal. This terminal may be used to operate some types of charge indicators, an ADLO system, a tachometer, or similar device by providing voltage pulses at a frequency of 8 pulses for each revolution of the alternator. The current draw of the accessories being powered through this terminal must not exceed 4 amperes. “R” terminals are normally of the unthreaded pin type.

When an “I” terminal is present it will be located on the side of the alternator opposite from the output terminal, in place of the “R” terminal. An “I” terminal is connected internally to the field circuit. An indicator light connected in series with this terminal will glow whenever there is a voltage difference between the “positive” side of the field circuit and the system voltage at other side of the indicator light. During normal alternator operation, the light will be off since the diode trio output voltage equals the system voltage. A side benefit of this circuit is that current is passed through the field winding during engine start-up, resulting in a lower alternator turn-on speed. A diode or resistor may be used instead of a light bulb if no indicator light is needed. (See Fig. 4) Up to 1 ampere of current may

be passed through this circuit to aid in alternator turn-on. An “I” terminal is normally a threaded stud type with a 10-24 thread.

A threaded 1/4" hole (with screw and lockwasher) in the rectifier end housing between the output and “R” or “I” terminal is provided to connect a ground lead if used; otherwise, the ground path is through the mounting hardware and brackets to the engine. On replacement units, a paper tag is present identifying the “ground screw”; remove and discard the tag. The screw and lockwasher should be installed in the housing regardless of whether a ground lead is connected, to prevent entry of dirt and water.

All electronic parts of the alternator are sealed in a compartment to keep out moisture and dirt, and the alternator is “inside cooled” by air drawn through a baffled inlet in the rectifier end cover and exiting from the drive end frame behind the fan.

### OPERATING PRINCIPLES

An alternator is a voltage-creating machine. The voltage regulator limits the maximum voltage that the alternator will produce at the output terminal by controlling the

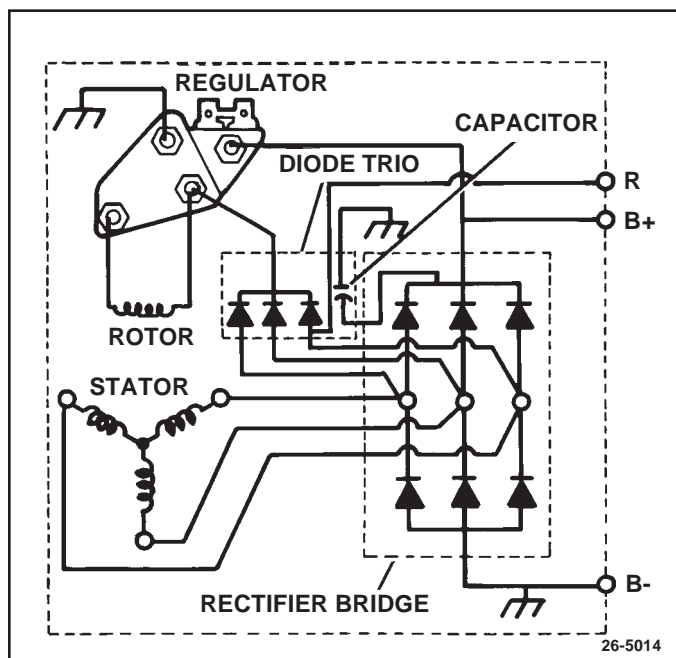

**Figure 6. Alternator Schematic with R Terminal**

magnetic field present in the stationary field. The output voltage, induced in the stator and rectified by the diodes, allows current to flow to satisfy the electrical loads placed on the system, up to a maximum current that is characteristic of the alternator design.

Schematics of the alternator circuitry are shown in Figure 6 (with “R” terminal) and Figure 7 (with “I” terminal). With the alternator rotor turning, a magnetic field around the stationary field coil is conducted by the rotor poles to

induce voltages in the stator windings. The faster the rotor turns, the higher the induced voltage will be.

The initial voltages at start-up are generated by residual magnetism in the rotor. On applications with an “I” terminal in use, this magnetism will be boosted by a small amount of current flowing through the field from the indicator light circuit. As speed and output increase, voltage available at the diode trio becomes sufficient to supply field current for normal operation. When the output voltage exceeds the battery voltage, the alternator begins to drive the system voltage. If the wiring system includes an indicator light, the presence of system voltage at the diode trio equalizes the voltage on both sides of the indicator light and the light goes out.

While the system voltage is below the voltage regulator setting, the regulator turns on the field current and allows the alternator to produce as much output as possible for the alternator speed (rpm), temperature and system voltage. When the voltage setting is reached, the regulator turns the field current off. When the field current is turned off, the magnetic field in the rotor collapses and the alternator output voltage begins to fall. The falling voltage causes the regulator to turn the field current back on and the magnetic field to rebuild. This switching action of the

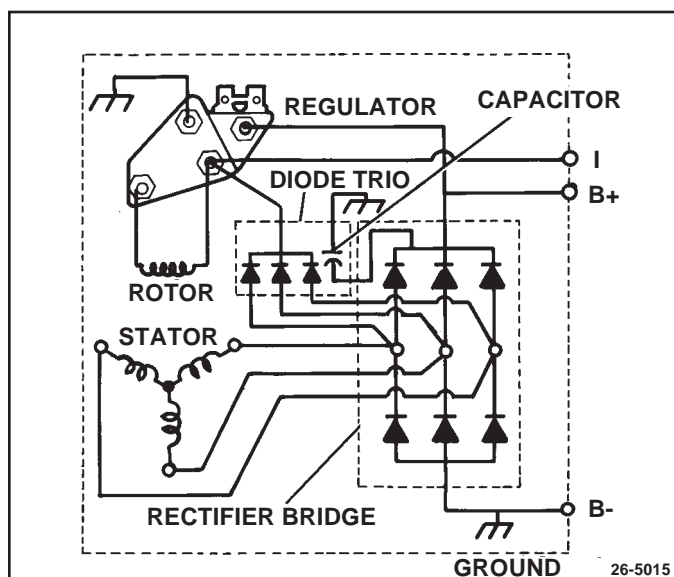

**Figure 7. Alternator Schematic with I Terminal**

regulator continues rapidly, keeping the output and system voltage very close to the voltage setting. This will continue unless the electrical demands of the system cause the system voltage to fall below the voltage setting. Should this happen, the regulator will again allow full field current to flow so that the maximum output of the alternator at the given speed, temperature and system voltage is realized.

An internal sense lead installed between the output terminal/diode heat sink and regulator stud, is used for voltage control.

## TROUBLESHOOTING

Trouble in the charging system will normally be indicated by one of the following:

- Indicator light “on” with engine running.
- Indicator light “off” with key on, engine not running.
- Undercharged or overcharged battery.
- Short life of light bulbs or other electric equipment caused by abnormally high system voltage.
- System voltmeter readings outside normal range.
- Incorrect or no operation of accessories connected to alternator “R” terminal.

Diagnose system as follows: (See Fig. 8)

## A. ALL CHARGING SYSTEMS -

## TEST EQUIPMENT NEEDED:

- Belt Tension Gage
  - Battery State-of-Charge Indicator
1. Check electrical system wiring and battery terminals for poor connections or other obvious conditions that might result in shorts, opens, grounds, or high resistance. Correct as necessary.
  2. Check alternator drive belt for proper tension. Adjust to manufacturer's specifications.
  3. Check battery for state-of-charge. If low, recharge according to manufacturer's specifications and load test to establish serviceability. Further diagnostic tests require a known good, fully-charged battery for accurate results.

## B. SYSTEMS WITH INDICATOR LIGHT -

## TEST EQUIPMENT NEEDED:

- Jumper Lead with 5-Amp Fuse

1. If indicator light is on with engine running:

Stop engine. Turn key switch to “run” position. Indicator light should be on. If not, go to Step 3.

Disconnect indicator light lead at alternator. This will be the “I” terminal connector.

If indicator light remains on, locate and correct shorted or grounded condition in indicator light circuit between the light and the alternator.

If indicator light goes out, light is working properly. Proceed to “C.” for check of system with indicator light working properly.

2. If indicator light does not come on with the key switch in the “run” position with the engine stopped (“bulb check” mode):

Leave key in “run” position with engine stopped. Disconnect indicator light lead from alternator. This will be at the “I” terminal. Use fused (5-amp) jumper lead to ground indicator lamp circuit in harness connector to ground screw or other clean metal ground on alternator housing.

- If indicator light comes on with jumper lead in place, repair or replace alternator as described under Unit Repair.

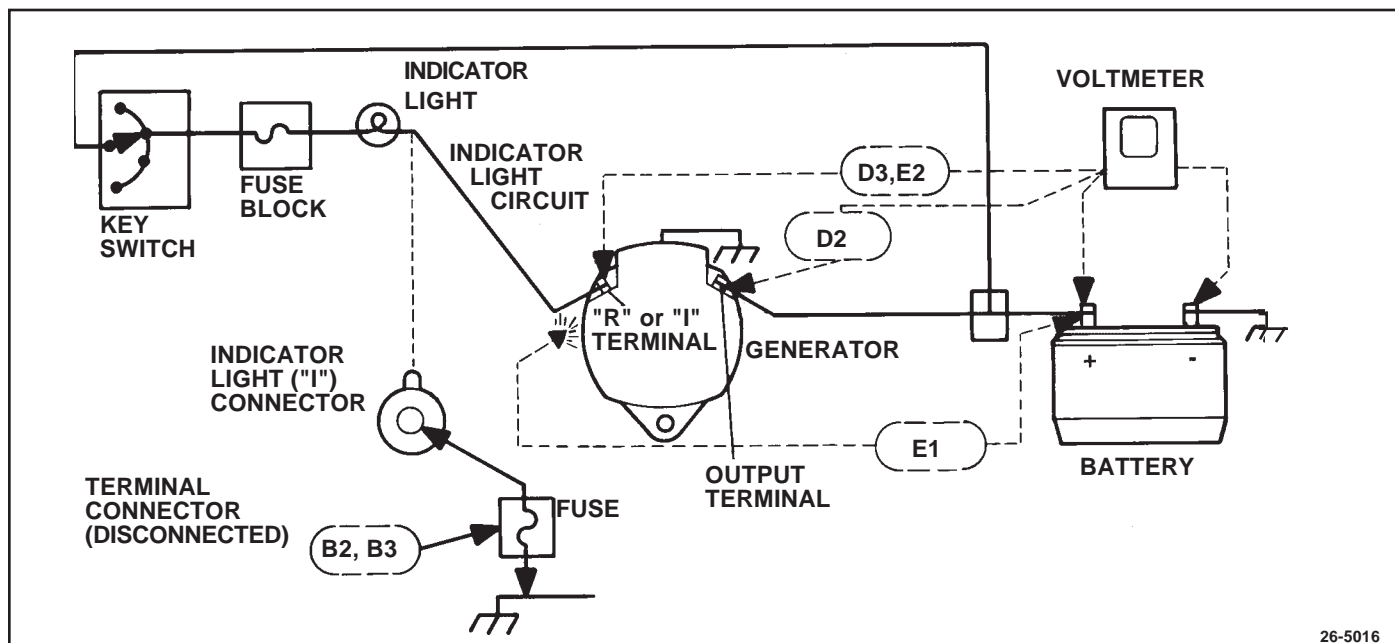

26-5016

Figure 8. Troubleshooting a 26-SI System

- If indicator light does not come on with jumper lead in place, verify that alternator is properly grounded by touching jumper lead to another ground source. If lamp still does not light, locate and correct open circuit in indicator light circuit. Circuit fuse may be open or light bulb may be burned out. Correct as necessary.
3. If indicator light comes on while engine is running, but is not on with engine stopped and key switch in "run" position:

Leave key in "run" position with engine stopped. Disconnect indicator light lead from alternator. This will be at the "I" terminal. Use fused (5-amp) jumper lead to ground indicator lamp circuit to alternator housing.

- If indicator light comes on with jumper lead in place, replace internal indicator light lead assembly or regulator as described under Unit Repair.
  - If indicator light does not come on with jumper lead in place, locate and correct open circuit in indicator light circuit between battery and light. Circuit fuse may be open. (With engine running, light is being powered by alternator and grounded through other circuits connected in parallel to indicator light circuit.) Correct as necessary.
4. If indicator light is on with key switch in "off" position:

Disconnect indicator light circuit at alternator.

- If indicator light remains on, locate and correct shorted condition between the light and alternator.
- If indicator light goes out, diode is shorted in rectifier. Locate and replace diode as described under Unit Repair.

### **C. SYSTEMS WITH VOLTMETER, NO INDICATOR LIGHT, OR WITH LIGHT WORKING PROPERLY -**

#### **TEST EQUIPMENT NEEDED:**

- Voltmeter

1. If battery is undercharged, indicator light remains on while vehicle is running, or system voltmeter shows operating voltage is below acceptable range:

With engine stopped and all electrical loads off, use voltmeter to check system voltage across battery terminals. Record voltage.

Start engine and run at moderate speed. Check system voltage across battery terminals with engine running.

- If voltage reading at battery terminals is different from reading showing at system voltmeter (if equipped), locate and correct cause of incorrect reading.
  - If voltage is lower than reading previously recorded with engine stopped, there is no alternator output. Proceed to section on No Output.
  - If voltage is higher than previous reading with engine stopped, alternator output is present. Proceed to Rated Output Check.
2. If battery is overcharged (as evidenced by excessive water use or electrolyte spewing from battery vents), or light bulbs or other electrical equipment have shortened life due to suspected high system voltage, or system voltmeter reads above normal range:

With fully charged battery, engine running at moderate speed and all electrical loads off, use voltmeter to check voltage at battery terminals.

For a 12-volt system, readings should be stable, around 13.5 - 14.5 volts and in no case go above 15 volts. For a 24-volt system, readings should be stable, around 27 - 28 volts and in no case go above 31 volts.

- One-wire system: If voltage is erratic or goes above 15 volts (31 volts on 24-volt system), check internal sense circuit and regulator as described under Unit Repair.

### **D. R TERMINAL ACCESSORY PROBLEMS**

1. Disconnect lead from "R" terminal.
2. Start engine and run at moderate speed. Check system voltage across battery terminals with engine running. Record voltage.
3. Use voltmeter to check voltage between "R" terminal and alternator ground screw or other clean metal ground.
  - If voltage is near half of system voltage, "R" terminal output is O.K. Note that this is a pulsating signal, so some voltmeters may give an unsteady reading.
  - If no voltage is present, replace diode trio assembly as described under Unit Repair.
  - If voltage is nearly the same as the alternator output voltage, disassemble alternator as described under Unit Repair and check to see if terminal is connected to diode trio lead. If so, replace diode trio assembly. If terminal is connected to regulator, it is wired as an "I" terminal and can't be used as an "R" terminal.

**E. NO OUTPUT****TEST EQUIPMENT NEEDED:**

- Voltmeter
- Jumper Lead (18 ga. min; no fuse)

Note that 26-SI alternators must be connected to a battery for the voltage sensing circuit to allow initial turn on (refer to section on Features). When properly connected and system checks indicate a “no output” condition, use the following steps to determine if the alternator requires repair:

**IMPORTANT**

On alternators with insulated output terminal, voltage in battery cable at output terminal cannot be checked by touching voltmeter to connecting bolt. Disconnect output terminal and check voltage at inner ring in terminal connector of cable.

1. For alternators without an “I” terminal in use, battery positive voltage at the output terminal and residual magnetism in rotor are necessary for alternator to turn on. With engine stopped, use voltmeter to verify that battery voltage is present in cable at output terminal. If not, locate and correct cause of voltage loss.

Residual magnetism in the rotor is sometimes lost during servicing of the alternator. The rotor can normally be remagnetized without removing alternator from application.

**CAUTION: Do not allow jumper lead to be accidentally grounded while connected to battery insulated terminal. If the free end of this lead is accidentally touched to the alternator housing or other grounded areas, the jumper lead may quickly get hot enough to cause a skin burn or to damage the jumper lead. Keep jumper lead carefully insulated from grounding during this procedure.**

To remagnetize rotor, make sure the normal connections are made to the alternator output terminal and to the ground circuit. Disconnect the wiring harness from the “R” terminal. Momentarily connect a jumper lead from battery positive to the alternator “R” (or unused “I”) terminal. (See Fig. 48) This will cause field current to momentarily flow through the field windings in the proper direction and restore magnetism. Reconnect wiring harness to “R” terminal, then recheck alternator for output.

2. For systems with an “I” terminal in use, the indicator light current at this terminal will establish normal magnetism at each engine start-up. Such systems may depend on this current to help ensure a low turn-on speed of the alternator. With engine stopped and key switch in “run” position, use voltmeter to check for

voltage present at this terminal. With “I” terminal connected and indicator lamp on, voltage will be less than battery voltage. If necessary to disconnect wiring at “I” terminal to make this check, check for battery voltage in harness wire. If voltage is present, proceed to Step 3. If no voltage is present, check “I” terminal circuit for cause of voltage loss (bulb may be burned out). Correct as necessary.

3. If no conditions have been found that might prevent the alternator from turning on (Step 1 or 2), remove alternator from engine in accordance with engine manufacturer’s instructions and proceed to Unit Repair.

**F. RATED OUTPUT CHECK****TEST EQUIPMENT NEEDED:**

- Voltmeter
- Ammeter (current capability at least 15 amperes higher than alternator rating)
- Variable Carbon Pile Load Test

**CAUTION: Failure to disconnect grounded battery cable at battery before removing or attaching battery cable at alternator output terminal may result in an injury. If a tool is shorted to the battery cable connector at the output terminal, the tool can quickly heat enough to cause a skin burn or the tool or cable may be damaged.**

1. Refer to Fig. 9 for test equipment hookups as described in following steps. If inductive pickup (“clamp on”) type ammeter is used, place current clamp on alternator output lead and skip to Step 4. If series ammeter is used, disconnect grounded battery cable at battery first.
2. Install ammeter in series with alternator output terminal.
3. Reconnect grounded battery cable at battery.
4. **NOTICE:** When a 12-volt carbon pile load test is used to diagnose a 24-volt system attach load test only to 12-volt potential in battery pack. Attaching a 12-volt load test to a 24-volt potential will damage the load test.

With load turned off, attach carbon pile load test across battery.

5. Attach voltmeter lead to grounded battery terminal, observing proper polarity for system. Leave other voltmeter lead open for checks at various points.
6. Check and record voltage at insulated battery terminal. For multi-battery systems, check voltage of battery set connected as if in battery charging mode.
7. With all system electrical loads off, start engine and run at moderate speed (rpm).



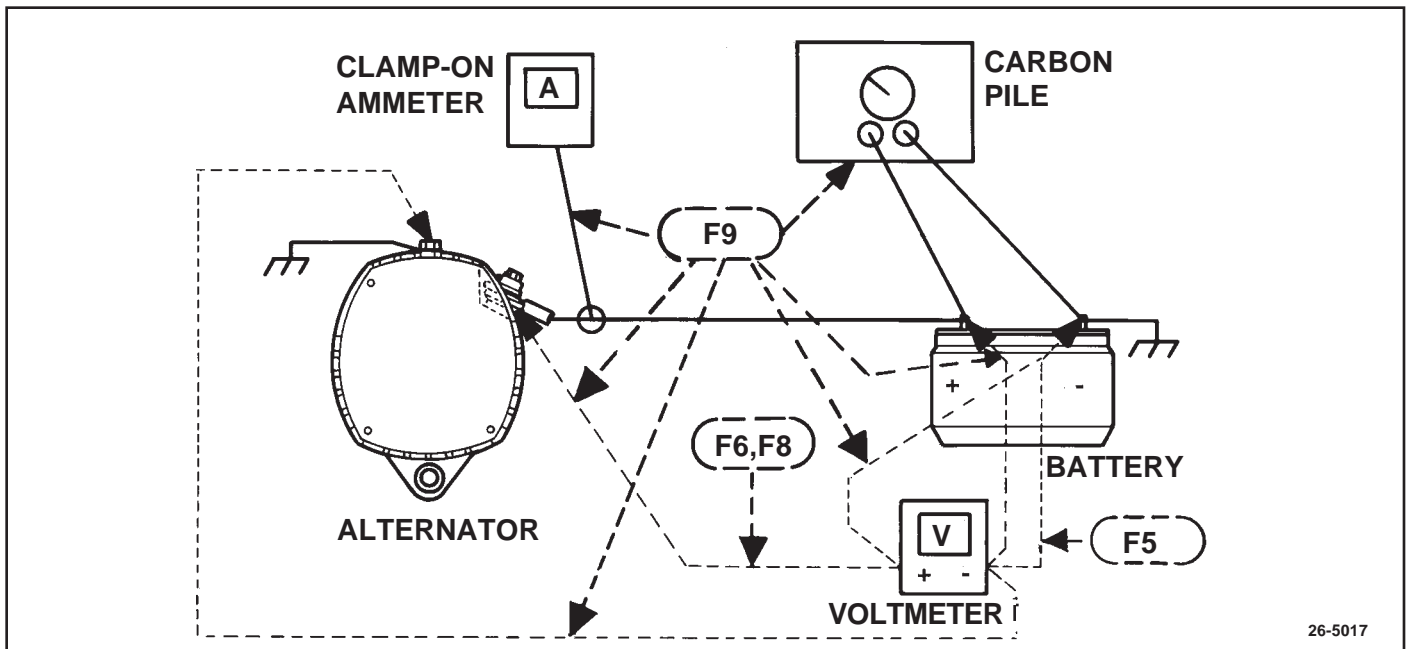

Figure 9. Rated Output Check

8. Recheck voltage at insulated battery terminal. Voltage should be higher than previous reading, but below 15 volts on 12-volt system (31 volts on 24 volt system).
  - If reading is lower than previous reading (Step 6), refer to section on No Output.
  - If reading is higher than 15 volts on 12-volt system (31 volts on 24-volt system), refer to section on High Voltage Output.
9. Turn carbon pile load on and adjust to obtain maximum alternator output on ammeter. Record maximum output.

With alternator still running at maximum output, check and record voltage drop in ground circuit between alternator housing and grounded battery terminal. Then check voltage drop from output terminal to battery positive. Turn carbon pile load off.

Maximum ampere output should be within 15 amps of output rating stamped on alternator identification plate, or as listed in Specifications section of this manual. Voltage drop should be 0.25 volts or less for each voltage drop test on 12-volt system (0.5 volts or less on 24-volt system).

- If ground circuit voltage drop is over 0.25 volts on 12 volt system (0.5 volts on 24-volt system), clean and tighten all ground circuit connections. If this does not correct excessive voltage drop, check ground circuit cables for improper sizing or high resistance conditions. Correct as necessary.
- If within 15 amps of rating, alternator is good. Look elsewhere for cause of problem.
- If more than 15 amps below rating, repair or replace alternator.

## ALTERNATOR UNIT REPAIR

**CAUTION:** Disconnect grounded cable at battery before removing or attaching battery cable at alternator output terminal. Otherwise, a tool shorted to the battery cable at the output terminal can quickly heat enough to cause a skin burn or damage the tool or cable.

**NOTICE:** Always reinstall fasteners at original location. If necessary to replace fasteners, use only correct part number or equivalent.

- If correct part number is not available, use only equal size and strength. For alternator internal fasteners, refer to Delco Remy America Standard Hardware Fasteners section in Service Parts Catalog.
- Fasteners that are NOT to be reused will be noted in procedure.
- Fasteners requiring thread locking compound will be noted in procedure.
- Use specified torque values when shown.

**CAUTION:** Using or replacing fasteners in any other manner could result in part or system damage.

If diagnosis determines that alternator repair is needed, remove alternator from engine according to manufacturer's instructions.

### DISASSEMBLY AND BENCH CHECKS

#### TEST EQUIPMENT NEEDED:

- Multimeter
- Regulator Tester

#### ALTERNATOR

1. Remove rectifier end plate (20), rectifier end cover (19), and gasket (47). (See Fig. 10)
2. Inspect electronics compartment (See Fig. 11) for contamination, for shorted or grounded wires, and for loose connections. If contamination is present, clean and dry compartment before proceeding. Check gasket for source of entry and replace as necessary.

If indicator light was not operating properly, check internal indicator light lead assembly for correct installation and continuity. Correct as necessary.

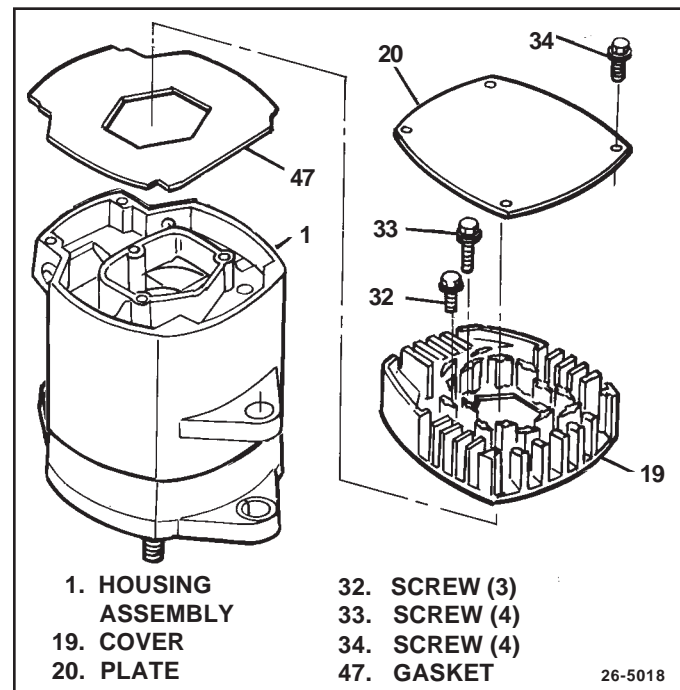

Figure 10. Removing End Plate and Cover

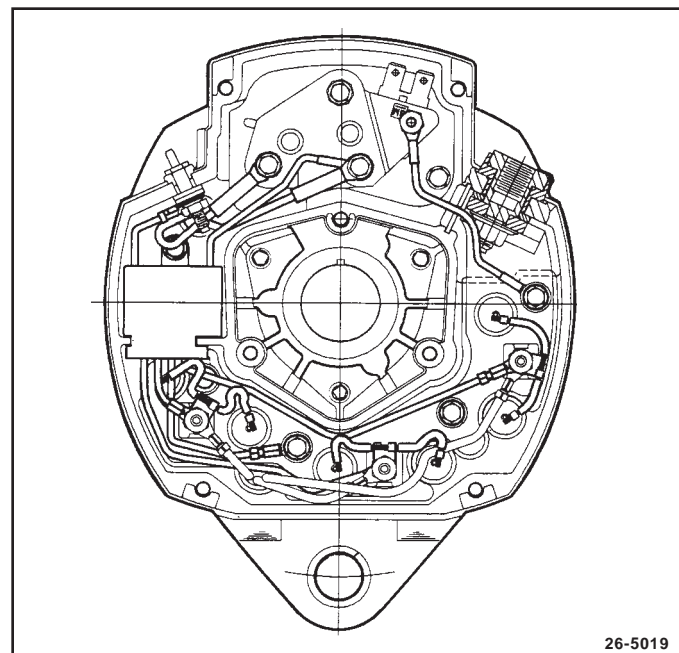

Figure 11. Electronics Compartment

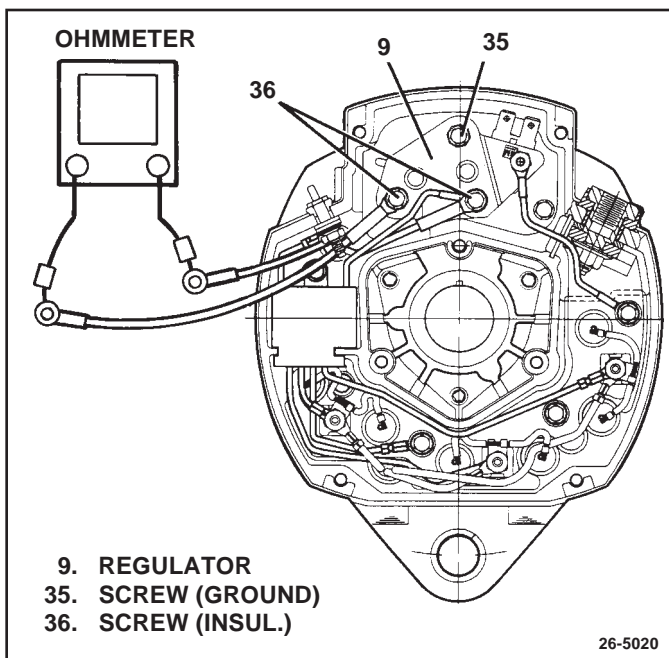

Figure 12. Checking Field Coil Resistance

### FIELD COIL

3. Disconnect 2 field leads from regulator (9) by removing 2 insulated regulator attachment screws (36). (See Fig. 12) Use ohmmeter to check resistance of field coil. Compare to Field Check ohms in Specifications at the end of this manual or from Service Specification Bulletin. If outside specifications, replace field coil as described later in this section.

### REGULATOR

#### 4. IMPORTANT

Back (metal side) of regulator and both sides of regulator mounting plate are coated with silicone heat transfer grease. If this grease is removed during testing, recoat as described under regulator installation in this section.

To remove regulator (9) for testing, remove sense lead nut (26) and grounded mounting screw (37). (See Fig. 13) It is not necessary to remove the regulator mounting plate (54), but it may come off with the regulator (if it does, pull the plate from the regulator and place it back in the alternator to keep from contaminating the grease). Check regulator on approved tester for SI type regulators. If regulator tests "good", return it to service. If it tests "bad", replace it. Install regulator as described later in this section.

### DIODE TRIO/CAPACITOR ASSEMBLY

5. Disconnect diode trio assembly's (15) 3 phase leads from the diode junction studs by removing the nuts

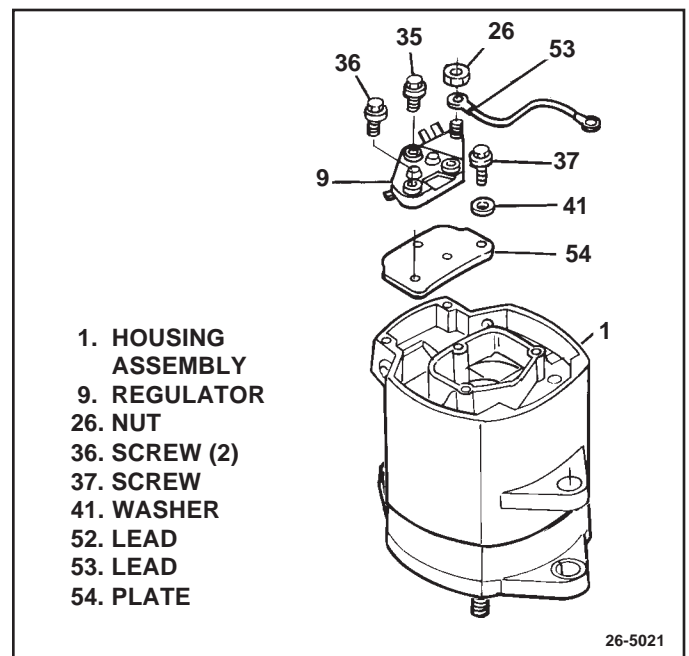

Figure 13. Removing Regulator

(25). (See Fig. 14) Disconnect diode trio assembly's capacitor lead from heat sink by removing screw (31) and insulator (51). If necessary to remove from alternator completely, disconnect diode trio assembly's "R" terminal lead (if used) from inside of "R" terminal by removing nut (25), then remove attaching screw (38) from grounding tab.

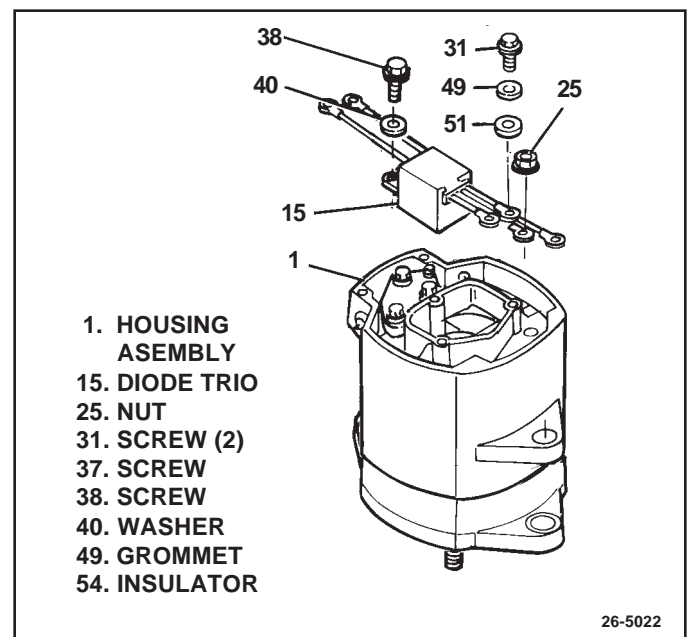

Figure 14. Disconnecting Diode Trio Assembly

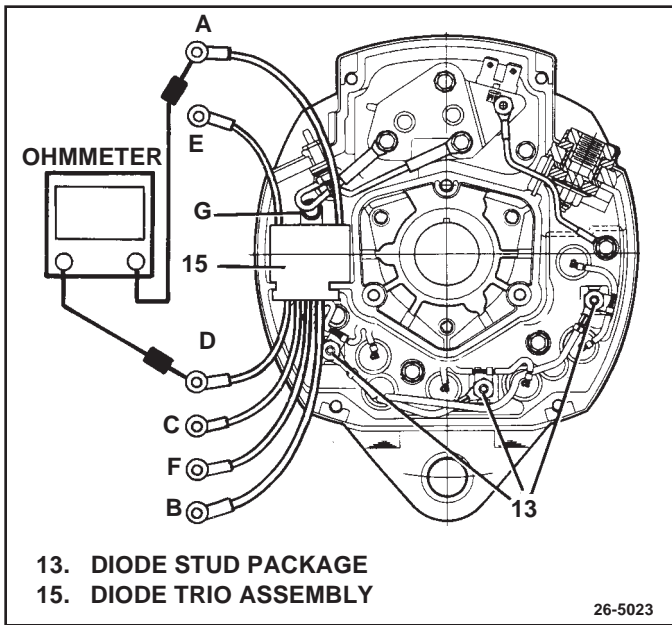

Figure 15. Electrical Check of Diode Trio Assembly

- Use ohmmeter or diode check function on multimeter to check diode trio (15). (See Fig. 15) Place negative ohmmeter lead on regulator lead (A) and use positive ohmmeter lead to check for continuity to each of the three phase leads (B, C, D). All three readings should indicate continuity. Reverse the ohmmeter leads and perform checks again. Readings should all indicate open circuits.

Using continuity check mode (diode check mode on digital meter), check for a shorted capacitor by touching ohmmeter leads to capacitor lead (F) and grounding tab (G). This check should show an open circuit.

If the alternator has an "R" terminal, check the "R" terminal circuit by checking for continuity between the "R" terminal lead (E) and each of the phase leads (B, C, and D). There should be continuity to one (and only one) of these leads.

If any of these checks are not as indicated above, replace the diode trio assembly (15). Install assembly as described later in this section.

### STATOR

- Disconnect the 3 stator phase leads from the diode junction studs by removing nuts (25). Use continuity check function of ohmmeter to check stator windings. (See Fig. 16) Place one meter lead on one of the stator phase lead connectors and check for continuity to each of the other two stator leads. There should be continuity to both. If not, one or more of the stator coils is open; replace the stator as described later in this section.

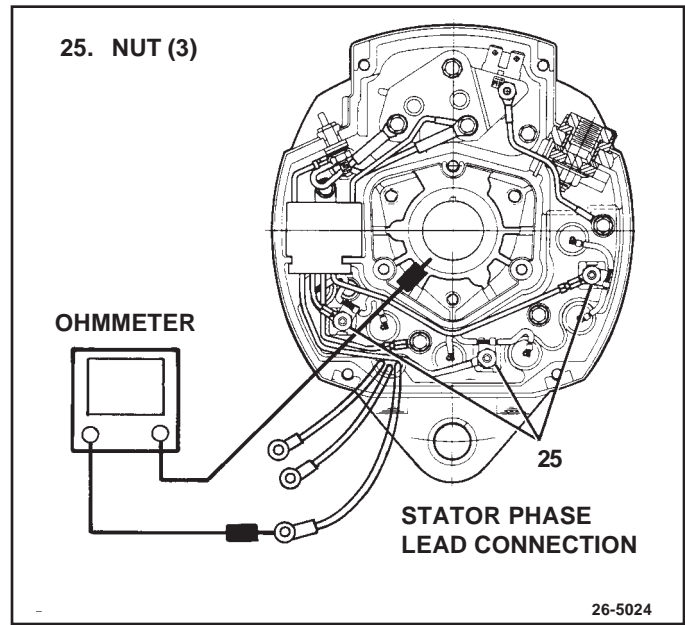

Figure 16. Checking Stator Windings

To check for grounds, again touch one meter lead to one of the stator phase leads, and touch the other meter lead to clean metal ground on the alternator housing. There should not be continuity. If there is continuity, the stator is grounded and should be replaced as described later in this section.

It is not possible to detect shorted stator windings with ordinary shop equipment. However, if all other electrical checks are normal and the alternator has exhibited low output, shorted stator windings may be the cause. In such cases, replace the stator as described later in this section.

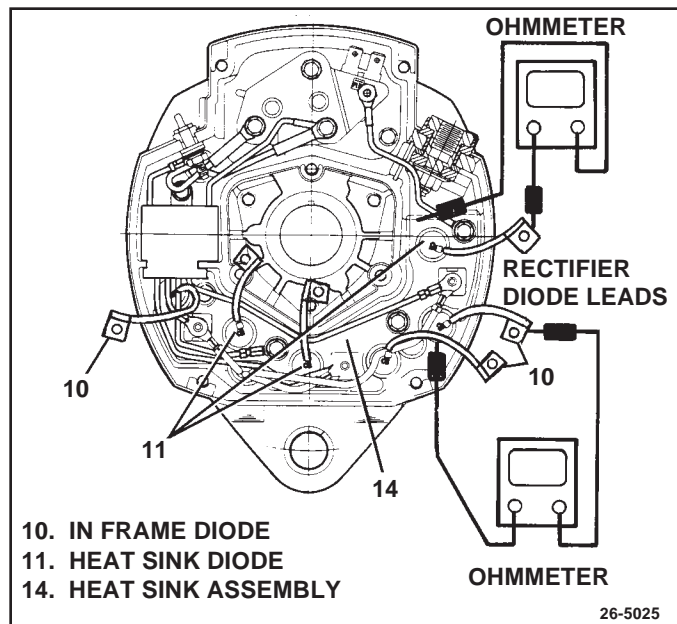

Figure 17. Checking Rectifier Diodes

**RECTIFIER DIODES**

- Disconnect the 6 diode leads from the 3 diode junction studs by removing nuts. (See Fig. 17) Find the three output side diodes (11), which are installed in the heat sink (12). These diodes will be identical in polarity and will commonly have the same color of insulation on the diode lead wire.

Use the ohmmeter or (for digital meters) the diode check function of the multimeter to check the diodes. Place one of the meter leads on a clean metal section of the heat sink and connect the other lead to each of the 3 diode lead connectors, without allowing the connectors to touch any other metal part. All 3 of these diodes should read nearly the same, either all "open" or all low resistance.

Reverse the leads and repeat these checks. All 3 diodes should again read nearly the same, but should be opposite from the first reading. If a diode reads the same (either "open" or low resistance) in both checks, replace it as described later in this section. If one diode seems to have polarity opposite from the other two, or if there is a question about whether the diodes are installed properly for the polarity of the alternator, refer to Fig. 18 for proper configuration.

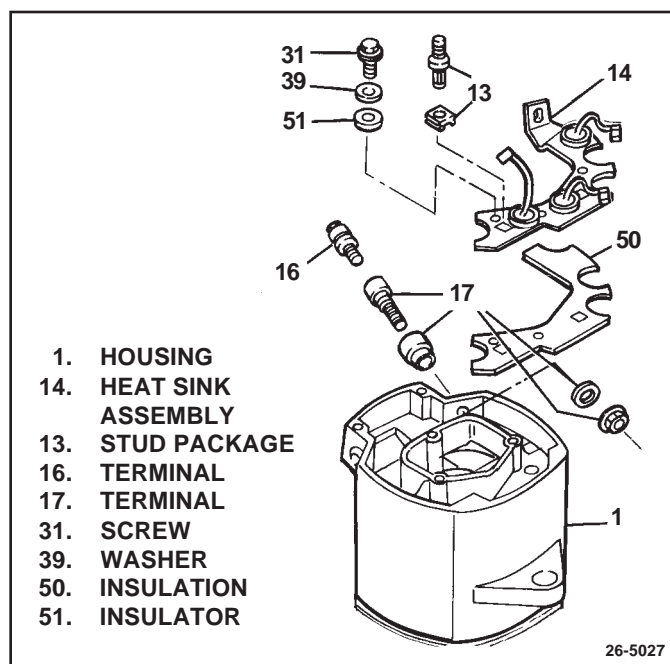

**Figure 19. Removing Heat Sink from Housing**

- Find the three ground side diodes (10) mounted in the rectifier end housing (1). (See Fig. 17) These diodes will be identical in polarity and will commonly have the same color of insulation on the diode lead wire. Repeat the diode check described above (Step 8), except use clean metal ground on the rectifier housing instead of the heat sink. Refer to Fig. 18 to determine proper polarity.
- To replace one or more of the rectifier diodes, disconnect all diode leads from the diode junction studs (13). Remove three heat sink attachment screws (31) and insulators (51), then remove the alternator output terminal (16) by removing the inside nut, washer, and insulator (17). (See Fig 19)

**! IMPORTANT**

Back of heat sink and both sides of heat sink insulator are coated with silicone heat transfer grease. If this grease is removed during testing, recoat as described under regulator installation in this section.

Remove the heat sink and diode assembly (14) from the rectifier end housing (1). (See Fig. 19) The insulator (50) between the heat sink and housing may come out with the heat sink. If it does, carefully peel it from the heat sink. Check insulator for damage that might result in a grounded condition and replace if necessary. If insulator is to be reused, place it back in the housing to prevent contamination of the grease.

ALTERNATOR GROUND	OUTPUT DIODES	GROUND DIODES
	CURRENT FLOW FROM	CURRENT FLOW FROM
NEGATIVE	LEAD TO HEAT SINK RED WIRES	HOUSING TO LEAD BLACK WIRE
POSITIVE	HEAT SINK IS LEAD BLACK WIRE	LEAD TO HOUSING RED WIRE

**Figure 18. Diode Polarity**

26-5026

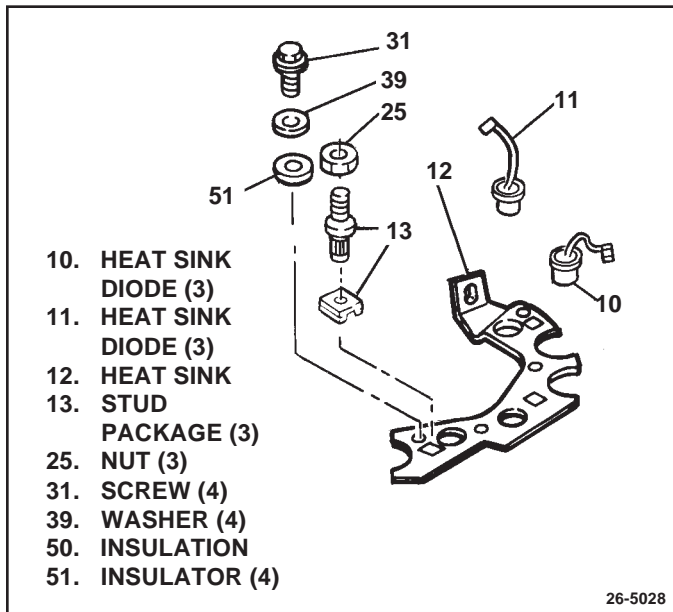

Figure 20. Removing Heat Sink Diodes

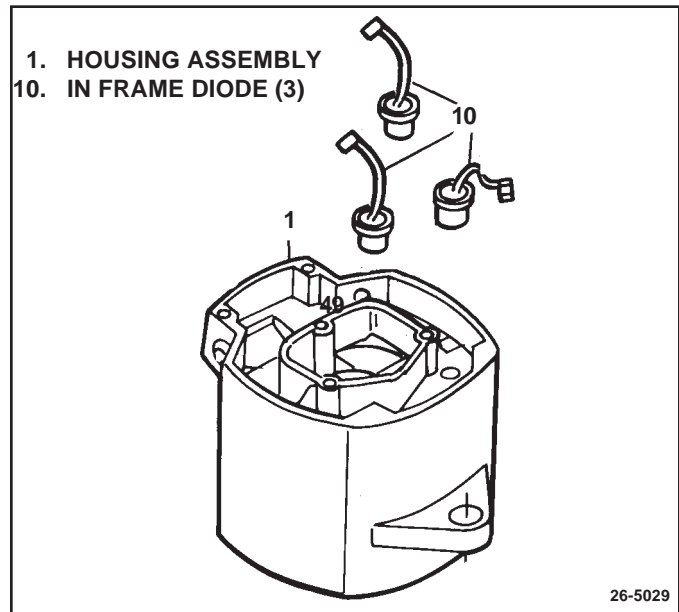

Figure 21. Removing Diodes from Housing

11. **NOTICE:** Do not hit diodes or diode mountings with a hammer or other tool. The shock of such an impact can damage the diode or other diodes in the same mounting. Use proper tools to press or pull diodes from their mountings.

Replacing one or more diodes requires the use of an arbor press or vise, and special diode removal and installation tools. Such tools are available from various automotive tool suppliers. When removing a diode (11) from the heat sink (12), (See Fig. 20) press diode from heat sink using an arbor press or vise. When removing a diode (10) from the rectifier end housing (1), (See Fig. 21) use a diode puller. As much as 890 N (200 lbs.) of force may be needed to remove a diode.

**FINAL DISASSEMBLY**

**NOTICE:** Do not damage exposed stator or field windings. Bumping or scraping these windings may break the insulation and leave a place for a short circuit or ground to develop later, causing the alternator to fail. Protect the windings from damage by careful handling.

12. To replace the field coil, stator assembly, rotor assembly, or drive end or rectifier end bearings, the drive end frame assembly must be separated from the rectifier end housing. (Fig. 22) Use 5/16" hex wrench or 5/16" hex drive, in the end of the shaft, to hold while removing shaft nut (27). Remove washer (42), pulley, and fan (23) from shaft, along with baffle and slinger

if used. Remove the 4 thru bolts (43). Carefully separate the drive end housing from the stator and rectifier end housing, taking care not to damage stator windings. (See Fig. 23)

13. To remove stator from rectifier end housing, be sure all 3 stator leads are disconnected from diode junction studs in electronics compartment. Pry stator (5) and

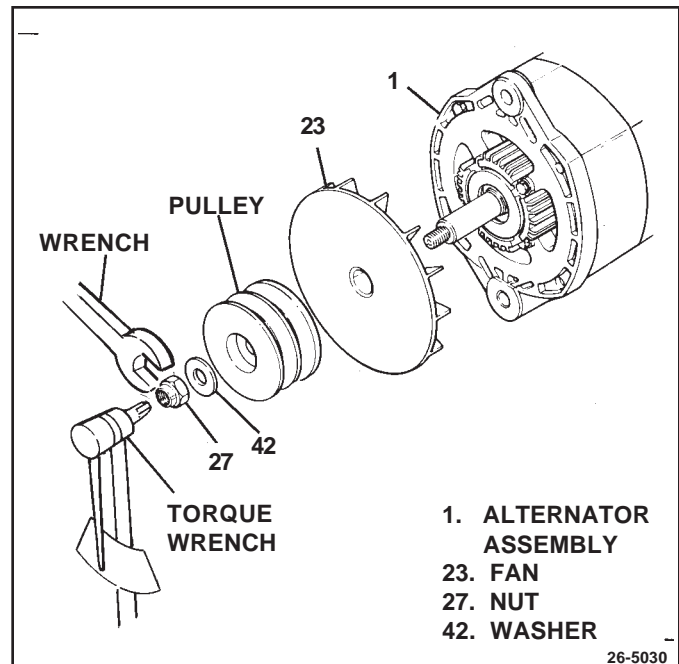

Figure 22. Alternator Disassembly

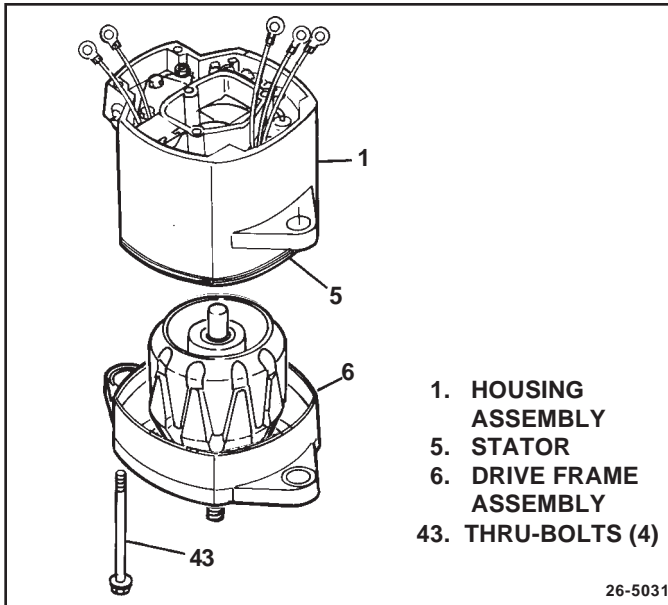

Figure 23. Separating Housings

housing (1) apart carefully. Guide stator leads and grommet (48) through hole as stator is pulled from housing. It may be necessary to push on grommet with a blunt instrument to unseat it from the housing. (See Fig. 24)

14. To remove field coil and support from rectifier end housing, (See Fig. 25) remove 3 field coil and support attaching screws (29). Lift coil and support from housing, while guiding field leads and grommet through hole.

15. To remove rectifier end bearing outer race (2) from housing, (See Fig. 26) use small screwdriver at slot to pry cap from housing.

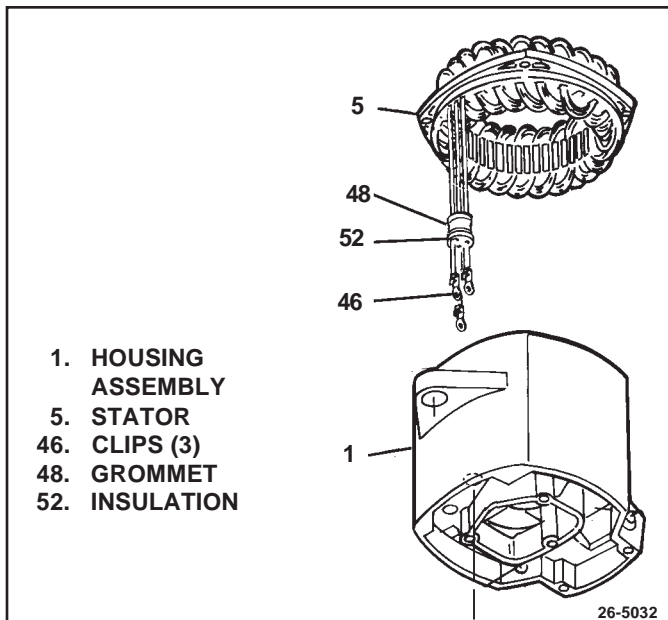

Figure 24. Removing Stator

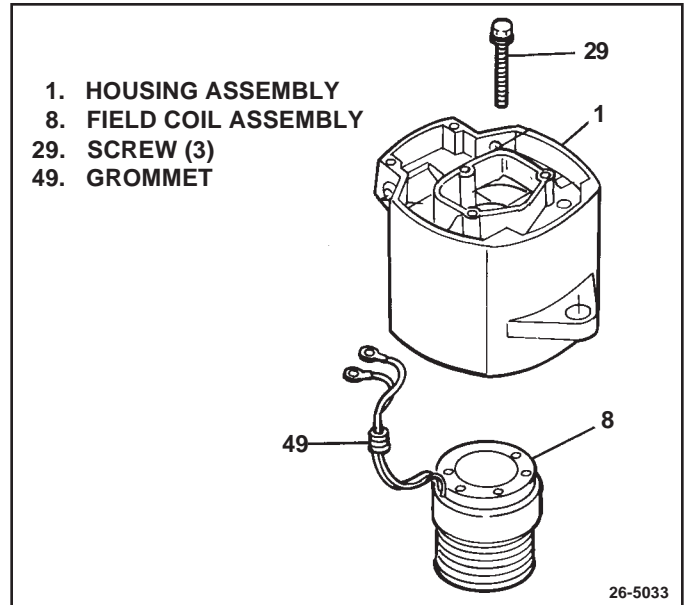

Figure 25. Removing Field Coil

**NOTICE:** Do not drive bearing out with hammer or other tool. Shocks from striking the rectifier end housing can damage diodes mounted inside. Use arbor press to push bearing from housing.

Wipe excess grease from bearing well, then press bearing through to inside of housing.

16. If bearing inner race (3) appears to be worn or rough, remove from rotor shaft (See Fig. 26) with a suitable puller.

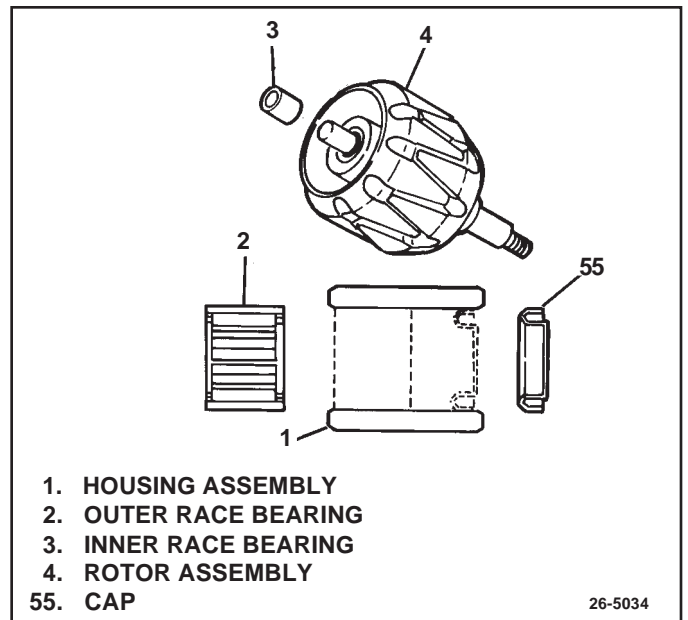

Figure 26. Removing Rectifier End Bearing

17. To replace rotor (4) or drive end bearing (7), (See Fig. 27) remove 4 bearing retainer attachment screws (28) from outside of housing (1). Lift rotor with bearing from housing, then pull bearing off of rotor shaft. If inside collar (22) appears rough or damaged, pull collar from shaft.

18. **NOTICE:** Do not drive mounting hinge bushing from lug on rectifier end housing with a hammer or other tool. Impact shocks from striking the rectifier end housing can damage diodes mounted inside. Use arbor press or vise to remove bushing.

To remove mounting hinge bushing (44) from lug on rectifier end housing (1), (See Fig. 28) press bushing from housing.

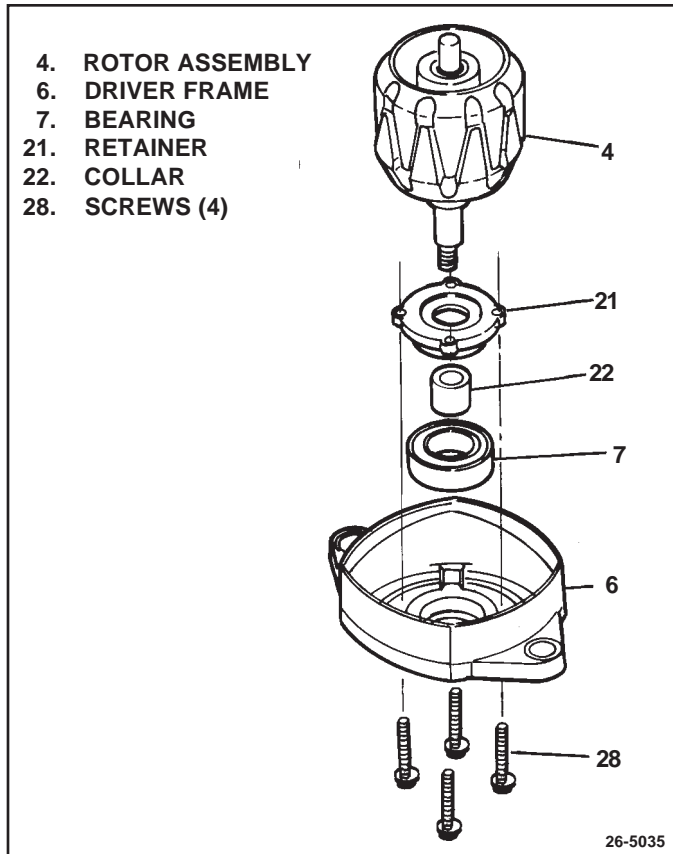

Figure 27. Disassembly of Drive End Components

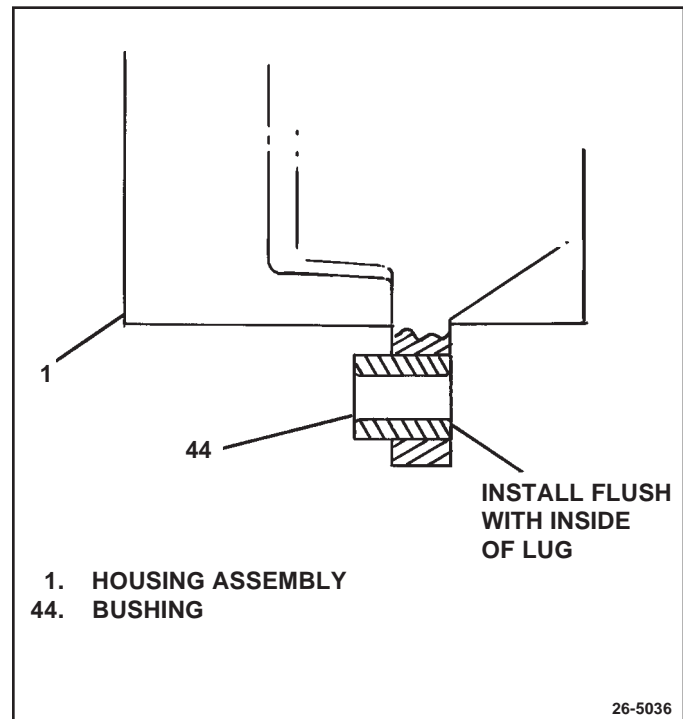

Figure 28. Removing Slip Bushing



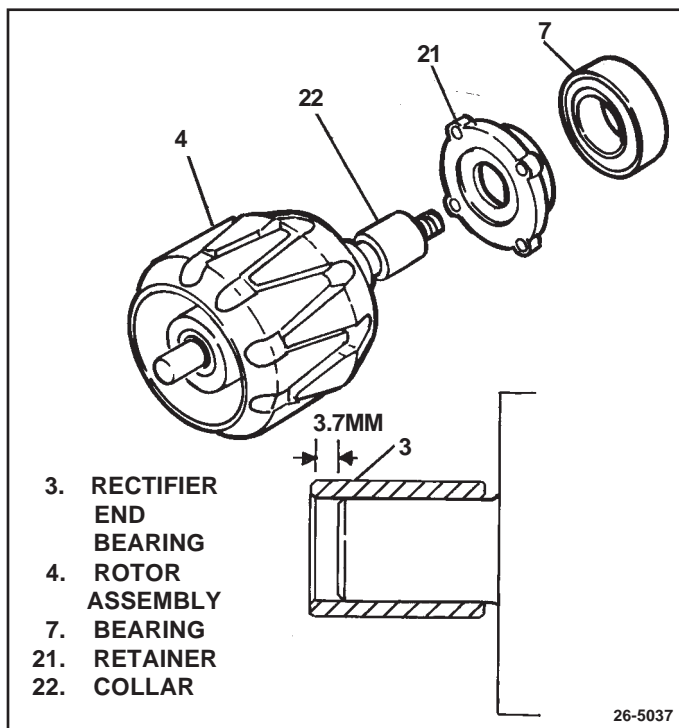

Figure 29. Rotor Assembly

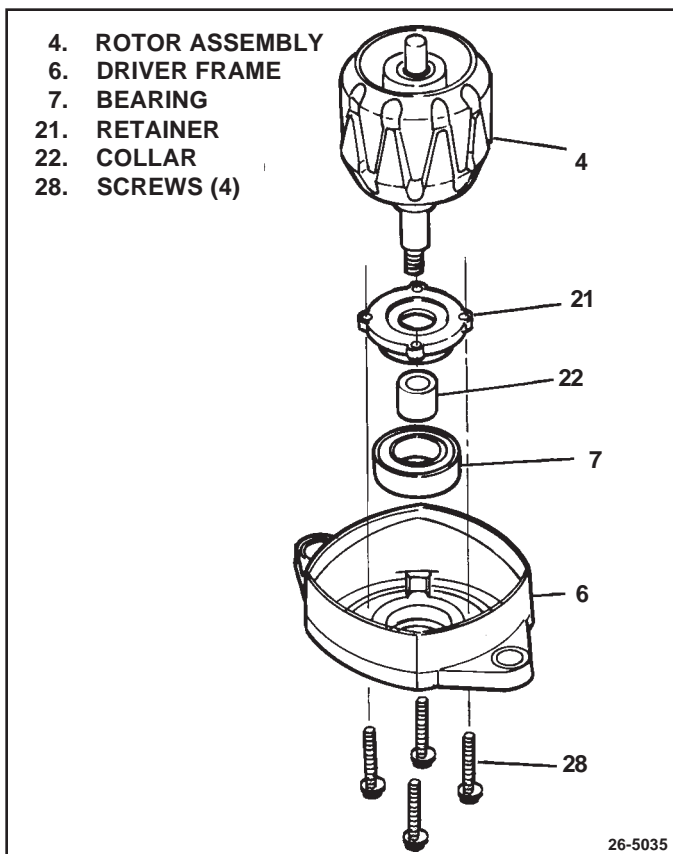

Figure 30. Installing Rotor in Drive End Frame

## ALTERNATOR ASSEMBLY

## ASSEMBLY OF DE FRAME AND ROTOR

## INSTALL OR CONNECT

1. Press inner race for rectifier end bearing (3) onto short end of rotor shaft. Stop when race is 3.7 mm (.15 in.) above end of shaft. (See Fig. 29)
2. Press inside collar (22) onto rotor shaft until collar is against shoulder on rotor (4). (See Fig. 29) Place retainer plate (21) onto collar (flanged side of retainer will face away from rotor, toward bearing). Using open tube that bears only on inner race of bearing, press new DE bearing onto rotor shaft until bearing is against collar.
3. Insert DE bearing (7) (on rotor shaft) into bearing well in drive end frame (6). (See Fig. 26) Bearing (7) will be a snug fit, but should slip in easily when properly aligned. Lubricate outside of bearing very lightly with ball and roller bearing lubricant (1948791) if necessary to facilitate assembly.
4. Hold drive end assembly (6) with long end of rotor shaft down so that bearing retainer plate (21) falls against housing (1), then align retainer with screw holes. (See Fig. 30) Start each of the four retainer attaching screws (28), then tighten screws gradually in sequence to pull retainer squarely against bearing.

## TIGHTEN

Bearing retainer attaching screws (28) to 5 N.m (45 lb. in.).

## IMPORTANT

To allow access for later installation of thru bolts, do not assemble fan and pulley to drive end assembly at this time.

## ASSEMBLY OF RECTIFIER END HOUSING AND COMPONENTS

## INSTALL OR CONNECT

5. **NOTICE:** Do not drive hinge bushing into lug on rectifier end housing with a hammer or other tool. Impact shocks from striking the end housing can damage diodes mounted inside. Use arbor press or vise to press bushing into place.

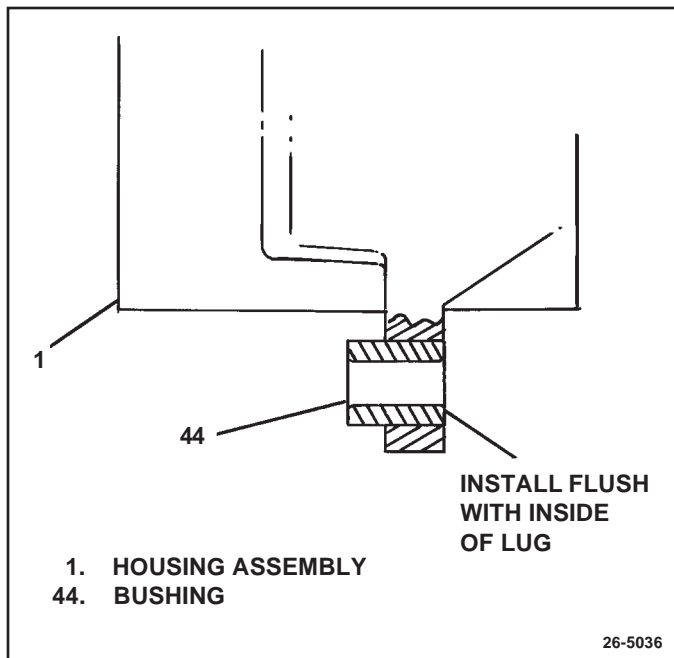

**Figure 31. Installing Slip Bushing**

Lightly lubricate outside surface of hinge bushing (44). Press hinge bushing into hole in lug on rectifier end housing (1). Install bushing flush with inside of lug to allow maximum distance between two hinge lugs for mounting. Final position of hinge bushing will be adjusted during mounting. (See Fig. 31)

6. Position new rectifier end bearing (2) to rectifier housing (1) so that seal will be toward rotor (4) as alternator is assembled. Press against seal side of bearing to assemble into housing until opposite end of bearing is 16.5 mm (.65 in.) from edge of housing. (See Fig. 32) Push cap into other end of housing until outside edges are flush with edge of housing.
7. Add ball and roller bearing lubricant (1948791) until cavity between plug (55) and bearing outer race (2) is about half full, placing grease so that it touches the edge of the outer race in several places around the outside of the bearing.
8. **NOTICE:** When installing diodes, do not hit diodes or diode mountings with a hammer or other tool. The shock of such an impact can damage the diode or other diodes in the same mounting. Use proper tools to press diodes into their mountings.

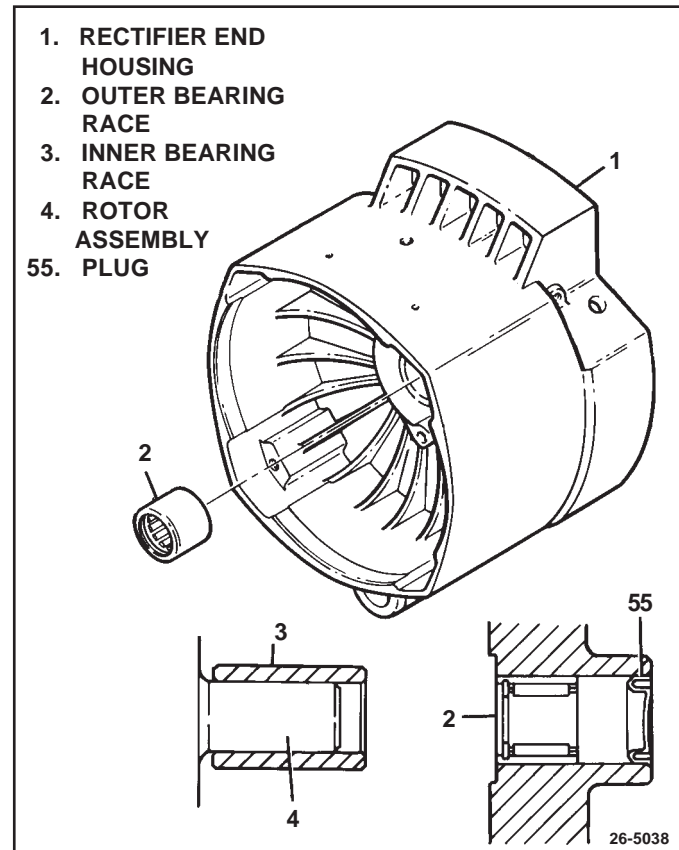

**Figure 32. Installing Rectifier End Bearing**

Use diodes only as specified in the Delco Remy America Service Parts Catalog when replacing diodes. Heat sink (output) diodes and in-frame (grounding) diodes will be similar in appearance except for color of wire insulation and color markings on the diode itself. The two types are opposite in polarity and must not be mixed. Also, the polarity of diodes used in negative ground systems will be opposite of those used in positive ground systems. Note that a new heat sink assembly comes with new diodes already installed. A new heat sink assembly may be installed instead of replacing individual output diodes, if desired.

Replacing one or more diodes requires the use of an arbor press or vise, and special diode removal and installation tools. Such tools are available from various automotive tool suppliers. When installing a diode, press diode into mounting using a tool that will bear only on the outer edge of the diode. As much as 890 N (200 lbs.) of force may be needed to install a diode.

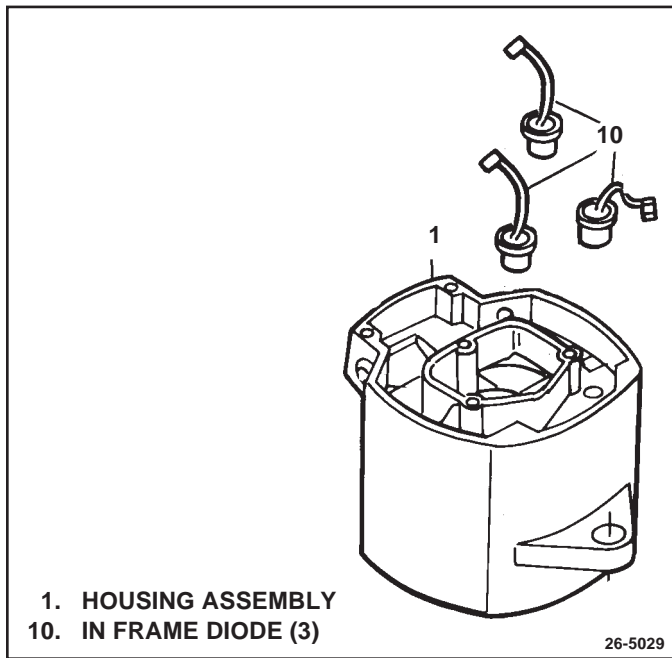

Figure 33. Installing In-Frame Diodes

- Position new in-frame diodes (10) to rectifier end housing (1) so that leads will reach the diode junction studs (13). (See Fig. 33) Using suitable diode installation tools, press new diodes into housing.
- Position new heat sink diodes (11) to heat sink (12) so that leads will reach the diode junction studs (13). (See Fig. 34) Using suitable diode installation tools, press diodes into heat sink.

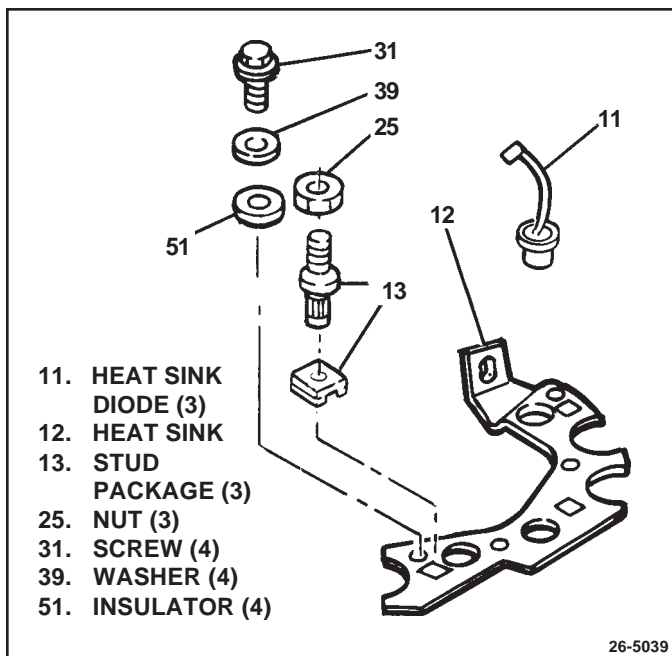

Figure 34. Installing Heat Sink Diodes

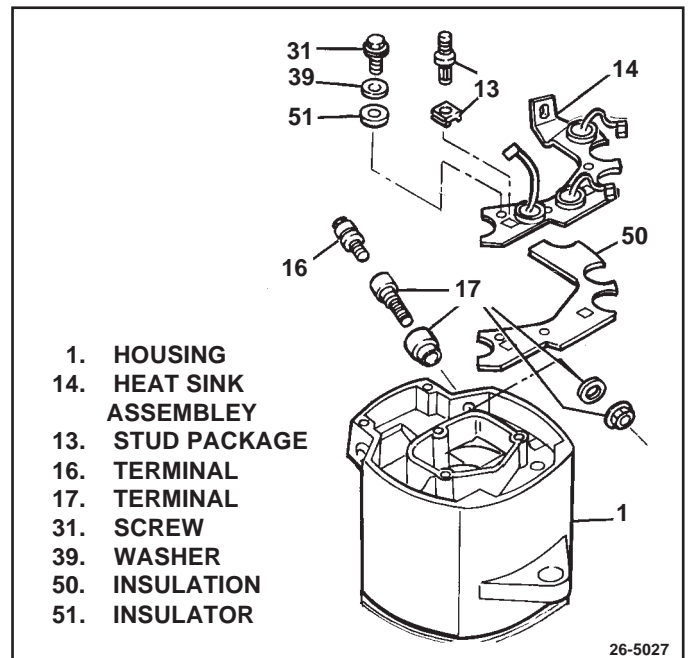

Figure 35. Installing Heat Sink

9. Push square plastic retainers for diode junction studs (13) into square holes in heat sink. Insert metal studs into holes in retainers and push in until shoulder on stud is seated against retainer. This spreads the retainer legs and secures the retainers in the holes. (See Fig. 34)

10. **!** IMPORTANT

Avoid getting silicone dielectric grease on diode lead clips or on electrical contact surfaces around mounting screw holes on top of heat sink. If grease does get on these areas, wipe away with a clean cloth slightly dampened with a grease-dissolving solvent and allow to dry.

Using silicone dielectric grease (1974984) for heat transfer, coat mounting area in rectifier end housing and both sides of insulator to be placed between diode heat sink and rectifier housing. Place insulator flat in rectifier end housing over mounting holes. Coat back side of heat sink with same grease, in the area where it will contact the housing. Position inside insulating washer for output terminal between hole in housing and slot in heat sink. Install heat sink assembly (14) to rectifier end housing (1) over insulator (50), aligning mounting holes. Install insulators (51), flat washers (39), and 2 heat sink attaching screws (31) that will not have electrical connections. (See Fig. 35) Insulators must be next to the heat sink. Finger tighten screws. Edge of insulator should be visible all around heat sink.

11. Place insulator (17b) on output terminal (17a) and install through hole in housing (1). (See Fig. 36) Install flat insulator washer (17c), aligning flat shoulders on terminal with slot in heat sink to fully seat terminal. Install nut/washer assembly (17d) onto threaded portion of terminal inside housing. Tighten nut to 5 N.m (45 lb. in.).

12.  **TIGHTEN**

Two previously installed heat sink mounting screws (31) to 3 N.m (26 lb. in.).

13. Lubricate grommet (49) on field coil leads lightly with petroleum jelly. Turn grommet and leads so that leads will be properly positioned after installation. (See Fig. 37) Place field coil and support (8) into rectifier housing (1), guiding leads through hole into electronics compartment and aligning mounting holes in support with screw holes in rectifier housing. Push grommet into hole in housing until fully seated. Install 3 field coil and support attachment screws (29).

14. **NOTICE:** Handle stator with care to avoid bending windings or breaking varnish insulation on windings. If windings are damaged before or during installation, they may become shorted and cause reduced alternator output.

Straighten stator leads to ease installation. Lubricate grommet (48) on stator leads lightly with petroleum jelly. Welded junction connector on stator must be

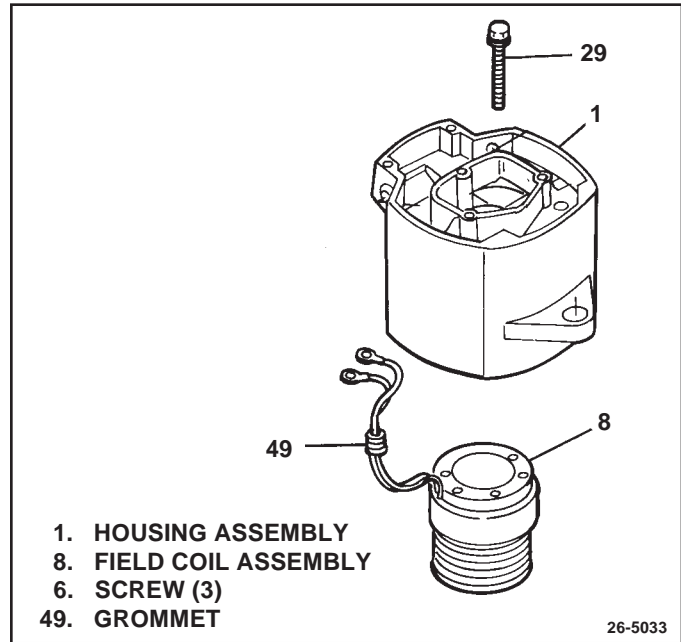

Figure 37. Installing Field Coil

positioned straight up from windings to prevent grounding to housing or rotor when alternator is assembled. Straighten stator lead wires all the way to the windings and insert through hole in housing into electronics compartment. (See Fig. 38)

Align thru-bolt holes in stator (5) with those in housing (1). Push stator into housing far enough to hold it in place, being sure grommet (48) on wires is inserted into hole in housing at the same time. Stator lead wires should be stiff enough to push grommet into hole as stator is installed (if not, carefully push on grommet with a blunt instrument to seat it in the hole). It is not necessary for the stator to be fully seated in housing at this time.

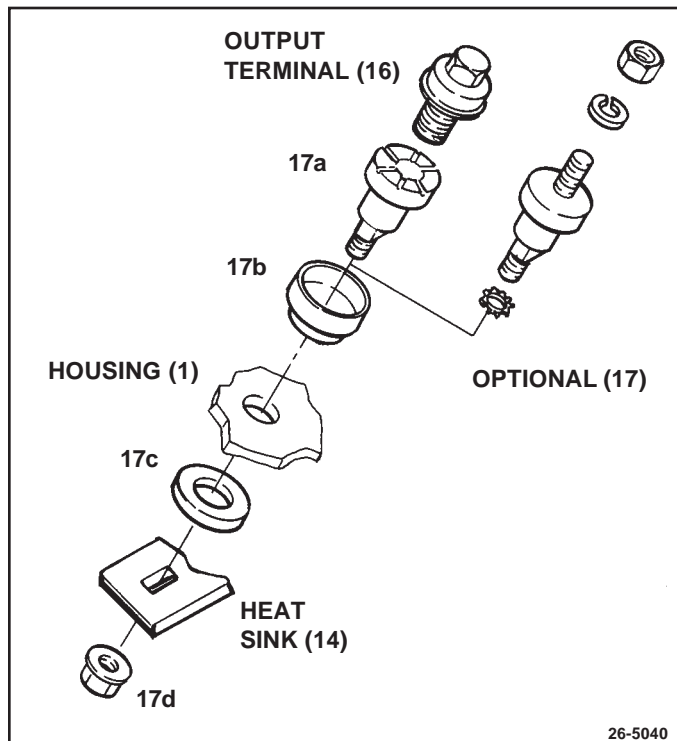

Figure 36. Installing Output Terminal

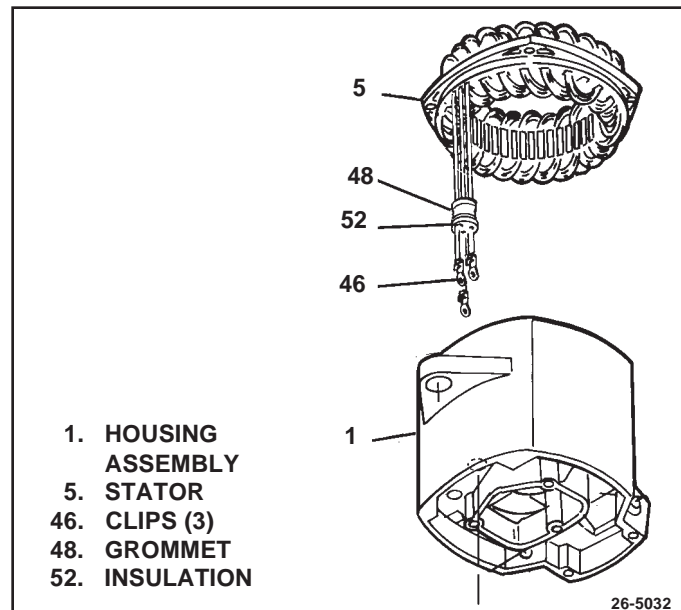

Figure 38. Installing Stator

## FINAL ALTERNATOR ASSEMBLY

15.  CLEAN

Inner race of rectifier end bearing (on rotor shaft) to prevent contamination of grease.

16. Align mounting lugs and assemble two halves of alternator (See Fig. 39), inserting rectifier end bearing inner race (on rotor shaft) into rectifier end bearing in rectifier housing. Do not fully seat drive end housing at this time.

17. Insert 4 thru-bolts (43) through drive end housing (6) and stator (5) into threaded holes in rectifier housing (1). Align housings and stator as needed to allow thru-bolts to stand straight in holes and engage threads. When all four thru-bolts are inserted, tighten them in round-robin fashion to fully seat both housings against shoulder on stator.

 TIGHTEN

Thru-bolts to 6.2 N.m (55 lb. in.)

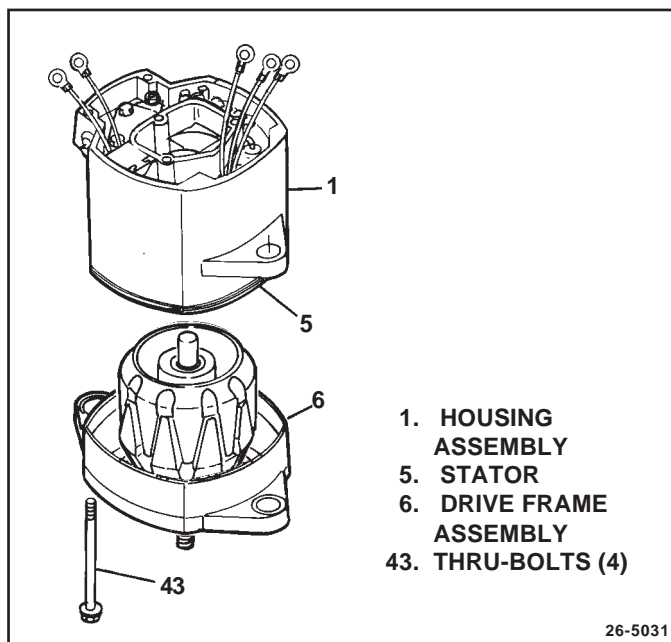

Figure 39. Assembly of Alternator Halves

18. Install diode trio assembly (15) to rectifier end housing. (See Fig. 40) Install diode trio and capacitor attachment screw (38). This screw provides a ground for the capacitor in the diode trio assembly and must hold tab securely. Tighten to 3 N.m (26 lb. in.).

NOTE: On 25-SI alternators that have been converted to 26-SI electronics, coat the threads of the attachment screw with high temperature adhesive/sealant (LoctiteC 272 or equivalent) prior to installation.

19. Place two diode lead clips onto each diode junction stud (13) in the heat sink assembly (14). Next, place one stator lead onto each of these studs, matching the length of the leads to the appropriate studs. Finally, place one yellow diode trio lead onto each stud, again matching the length of the lead to the appropriate stud. Install a diode trio to stator lead attaching nut (25) onto each diode junction stud. Position clips under nuts so that leads are routed without being pinched or pulled tight against sharp surfaces. Tighten nuts to 3 N.m (lb. in.).

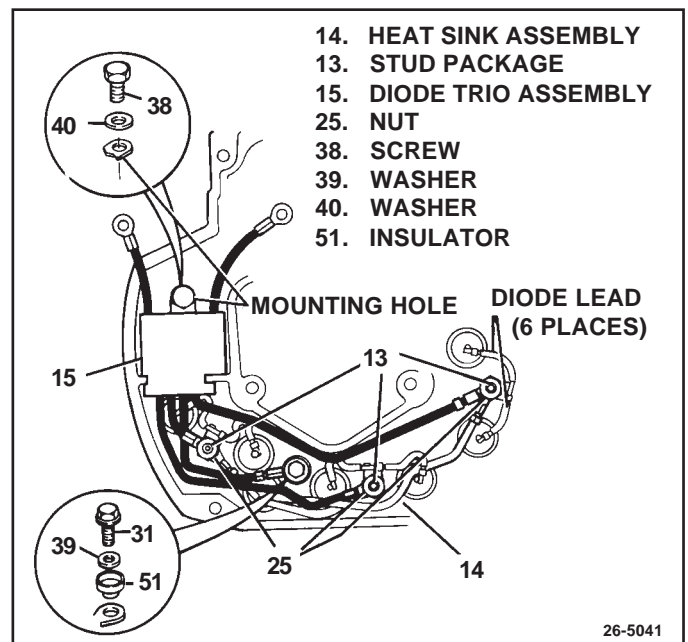

Figure 40. Installing Diode Trio Assembly

- Place clip of red diode trio lead over hole in heat sink, then install insulator (51), flat washer (39), and heat sink attachment screw (31). (See Fig. 40)



Heat sink attachment screw to 3 N.m (26 lb. in.).

- Place "R" or "I" terminal (18) into hole in rectifier housing (1). Place insulating washer and plain washer onto stud inside housing. (See Fig. 41) If alternator uses "R" terminal, place yellow "R" terminal lead from diode trio assembly (15) onto inside terminal stud (18). If alternator has "I" terminal, install indicator light lead assembly onto inside terminal stud. Install inside terminal nut. Hold external hex portion of terminal as anti-turn.



Inside "R" or "I" terminal nut to 2.3 N.m (20 lb. in.).

- Coat regulator mounting area in rectifier end housing (1) and both sides of regulator mounting plate (54) with silicone dielectric grease (1974984). Place plate into rectifier end housing, aligning holes with those in the housing. If unit uses a regulator mounting plate attachment screw (37) (1/2" long), install screw/washer assembly (41) to hole A. (See Fig. 42) Finger tighten.

NOTE: On 25-SI alternators that have been converted to 26-SI electronics, a spacer is installed between the plate and housing at hole C prior to installing the plate. Coat both ends of spacer with silicone dielectric grease before placing over hole C in housing.

- Coat back (metal side) of regulator (9) with silicone dielectric grease (1974984). Place regulator onto mounting plate, aligning mounting holes with those in rectifier end housing. Install regulator grounding attachment screw/washer assembly (35) (1" long) through regulator and mounting plate into housing hole D. Finger tighten.

- Place "I" terminal lead (if used), blue lead from diode trio, and long field coil lead over hole B (See Fig. 42) and insert insulated regulator attachment screw (35) (1" long). Place short field coil lead over hole C and insert insulated regulator attachment screw (36) (1" long). Finger tighten both screws.

NOTE: On 25-SI alternators that have been converted to 26-SI electronics, the insulated attachment screw that is used in hole C will be 2" long. A spacer is used under the plate. Coat threads on screw with high temperature adhesive/sealant (LoctiteC 272 or equivalent) prior to installing in hole C.

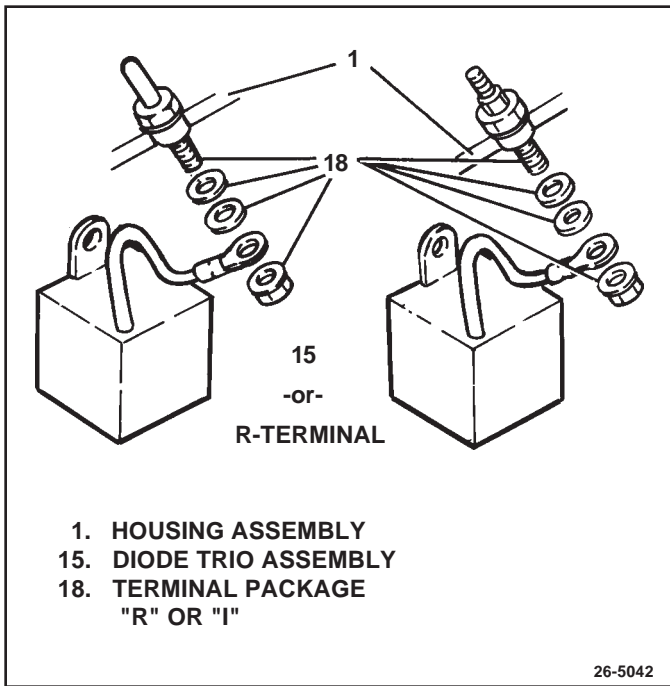

Figure 41. Connecting "R" Terminal

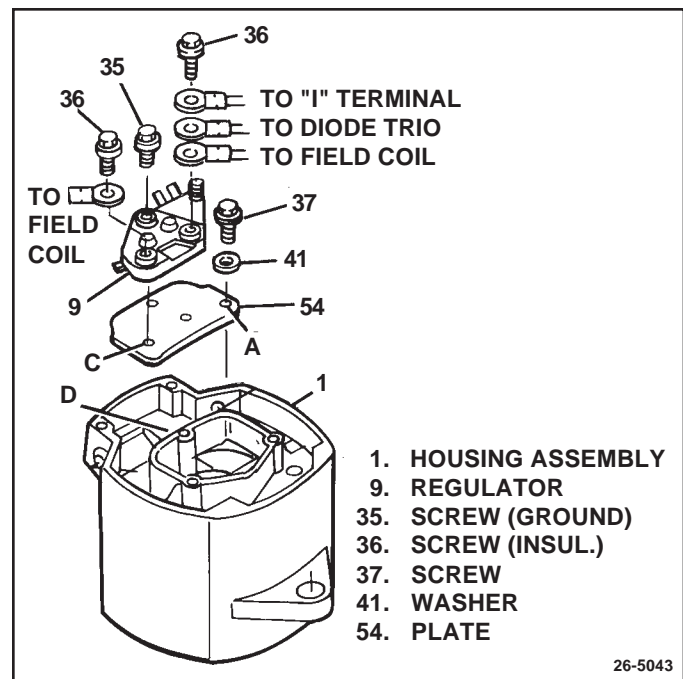

Figure 42. Installing Regulator

25.  TIGHTEN

Regulator and mounting plate screws (holes A, B, C, and D) to 3 N.m (26 lb. in.).

26. Insert regulator lead support (57) into slots in housing (1). (See Fig. 43) Place one end of lead to diode heat sink lead (sense lead) over mounting hole in heat sink. Add insulator (51), flat washer (39), and heat sink attachment screw/washer assembly (31). Clip on lead must be under the insulator, next to the heat sink. Finger tighten attachment screw. Place other end of lead over stud on regulator, routing lead through slot in lead support. Install regulator stud nut (26).

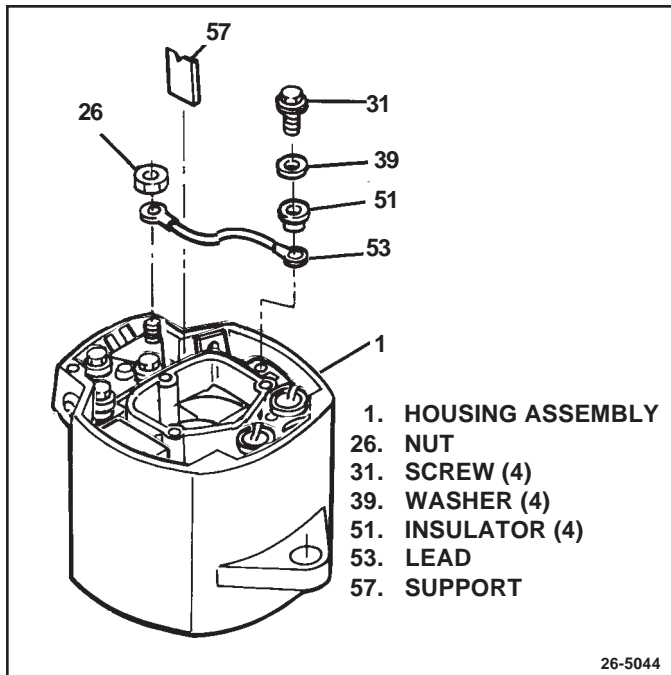

Figure 43. Installing Regulator Lead

 TIGHTEN

Heat sink attachment screw each to 3 N.m (26 lb. in.) and regulator stud nut to 2 N.m (18 lb. in.)

- 27. Check all connections and fasteners in the electrical compartment for tightness. Fig. 44 shows location of fasteners with torques referenced in this bulletin. Check wires to be sure they are not routed against sharp edges.
- 28. Edges of end cover gasket (47) must be free of cracks or other deterioration to assure sealing of the electronics compartment, both around the outside and around the

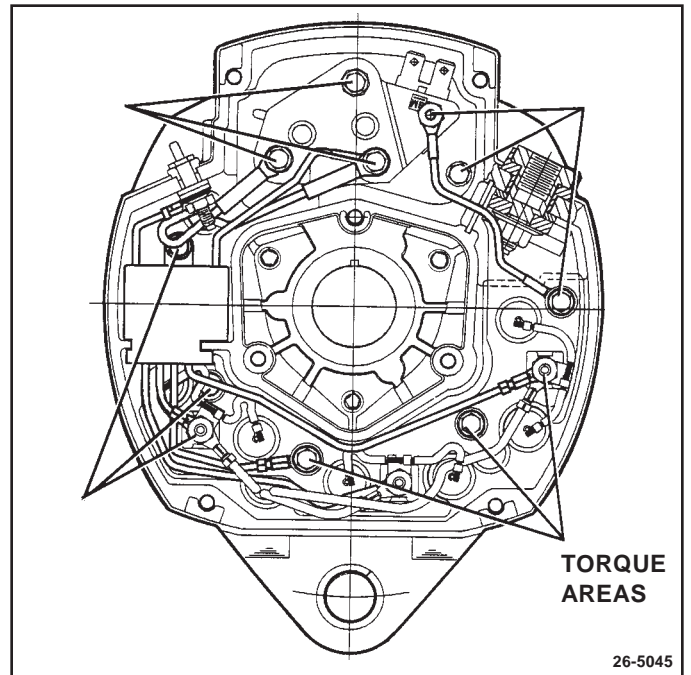

Figure 44. Fastener Torques

center hole. Replace gasket with a new one if at all questionable. Wipe edges of rectifier end housing and end cover gasket clean of foreign material. Place gasket and cover (19) onto housing (1) and install 7 rectifier cover attachment screw/washer assemblies (32 & 33). (See Fig. 45)

**TIGHTEN**

Rectifier cover attachment screws to 5.3 N.m (47 lb. in.).

29. Install rectifier end plate (20) with 4 rectifier cover plate attachment screws (34). (See Fig. 45)

**TIGHTEN**

Cover plate attachment screws to 3 N.m (26 lb. in.).

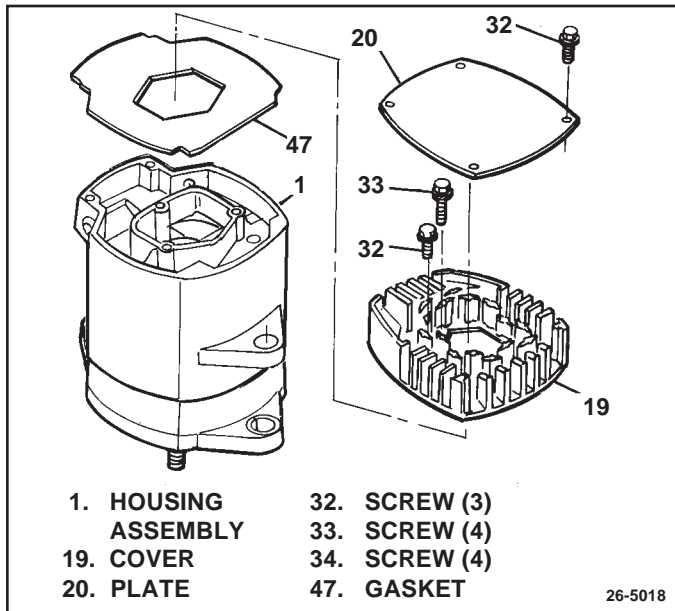

Figure 45. Installing Gasket, Cover, and End Plate

30. Install spacer and slinger to DE frame on models so equipped (refer to Service Parts section of this manual). Place fan (23) onto rotor shaft with vanes toward body of alternator, (See Fig. 46) followed by baffle, if used. Install pulley suitable for engine application. Several pulley styles are available from AC-Delco for 7/8" shaft alternators, including a blank that can be custom machined for unique applications. Place shaft nut washer (42) and shaft nut (27) onto shaft. The shaft nut should be positioned with flat side next to washer.

**TIGHTEN**

Hold shaft with 5/16" hex wrench or hex driver inserted in end of shaft. Holding the shaft with a hex driver installed on a torque wrench makes an ideal way to check torque while tightening the nut. Tighten pulley nut to 102 N.m (75 lb. ft.).

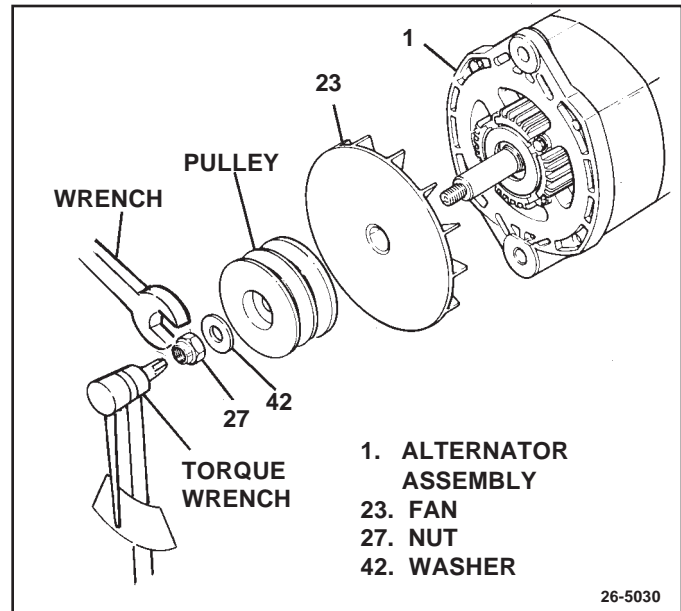

Figure 46. Installing Fan and Pulley



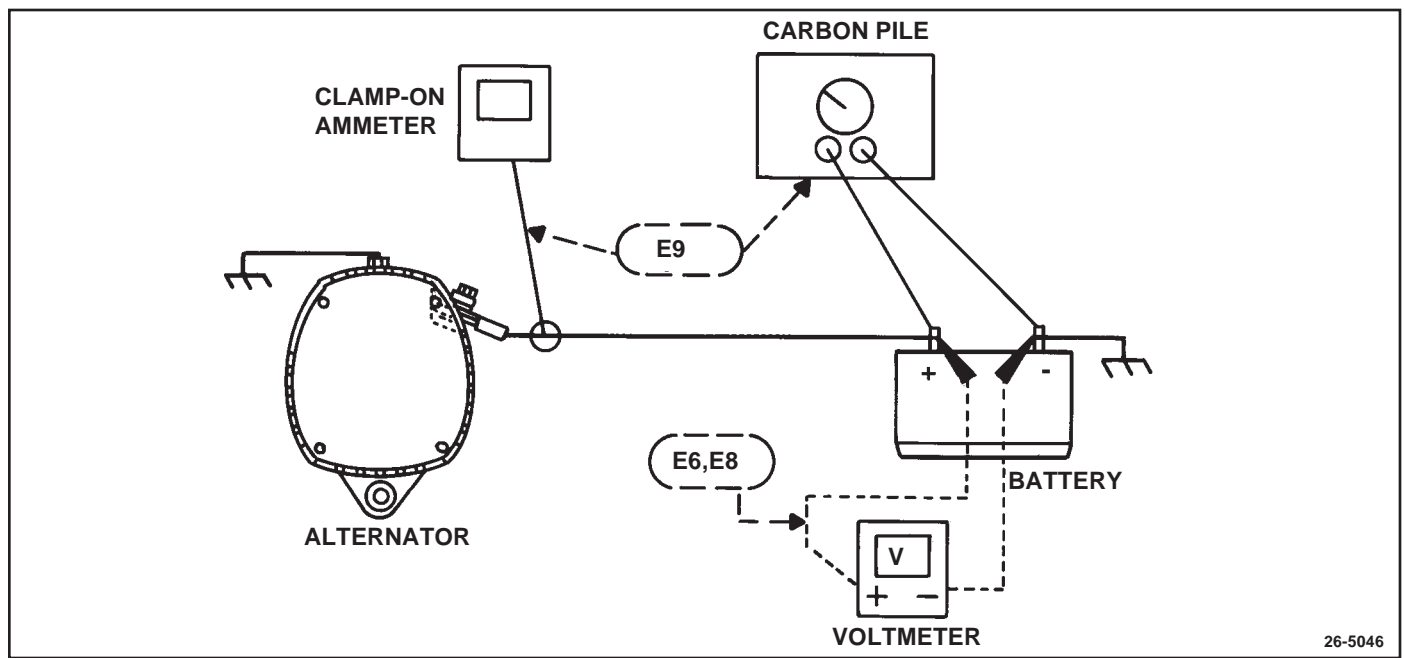

Figure 47. Alternator Bench Test

## ALTERNATOR BENCH TEST

### TEST EQUIPMENT NEEDED:

- Alternator Test Stand (5000 rpm capability at least 5 HP)
- Battery or Battery Set (fully charged)
- Variable Carbon Pile Load Test
- Ammeter (current capability at least 15 amps higher than alternator rating)
- Voltmeter
- Ohmmeter

The bench test procedure will verify alternator performance prior to installation on the vehicle. This test checks the alternator output in the same manner as the Rated Output Check covered earlier. If bench test equipment is not available, install the alternator on the engine according to manufacturer's instructions and repeat the Rated Output Check to verify alternator operation. If bench test equipment is available, proceed as follows:

1. Mount alternator in test stand according to test stand manufacturer's instructions.

2. **!** **IMPORTANT:** Battery or battery set must be fully charged for test results to be valid.

**NOTICE:** When a 12-volt carbon pile load test is used to diagnose a 24-volt system, attach load test only to 12-volt potential in battery set. Attaching a 12-volt load test to a 24-volt potential will damage the carbon pile.

With carbon pile load turned off and with battery or battery set fully charged, make electrical connections as shown in Fig. 47. Battery voltage and ground polarity must be same as system in which alternator is used. Check and record battery or battery set voltage before proceeding with test.

3. With carbon pile load "off," start test stand and slowly increase alternator speed to highest rpm shown under Cold Output specifications in 26-SI Alternator Specifications at the end of this manual. Observe voltmeter.
  - If voltage does not increase but remains at or below previous reading (Step 2), there is no alternator output. Turn carbon pile load off and stop test stand. Residual magnetism in rotor may have been lost. Skip to Step 5.

- If voltage increases above 15 volts on 12-volt system (or above 31 volts on 24-volt system), voltage is uncontrolled. Turn carbon pile load off and stop test stand. Recheck alternator for proper assembly. If alternator has been assembled properly, replace regulator as described under Unit Repair. Also check field coil for shorts and replace if defective.
  - If voltage is proper, proceed to next step.
4. With alternator running at highest rpm shown under Cold Output in Specifications, turn on carbon pile load and adjust to obtain maximum alternator output on ammeter.
    - If ammeter reading is within 15 amps of Cold Output in Specifications, alternator is good. Turn off carbon pile load and stop test stand.
    - If ammeter reading is more than 15 amps below specification, alternator is not operating properly. Turn off carbon pile load and stop test stand. Return to Unit Repair section in this manual and re-diagnose the alternator.
  5. **CAUTION:** Do not allow jumper lead to be accidentally grounded while connected to battery insulated terminal. If the free end of this lead is accidentally touched to the alternator housing or other grounded areas, the jumper lead may quickly get hot enough to cause a skin burn or to damage the jumper lead. Keep jumper lead carefully insulated from grounding during this procedure.

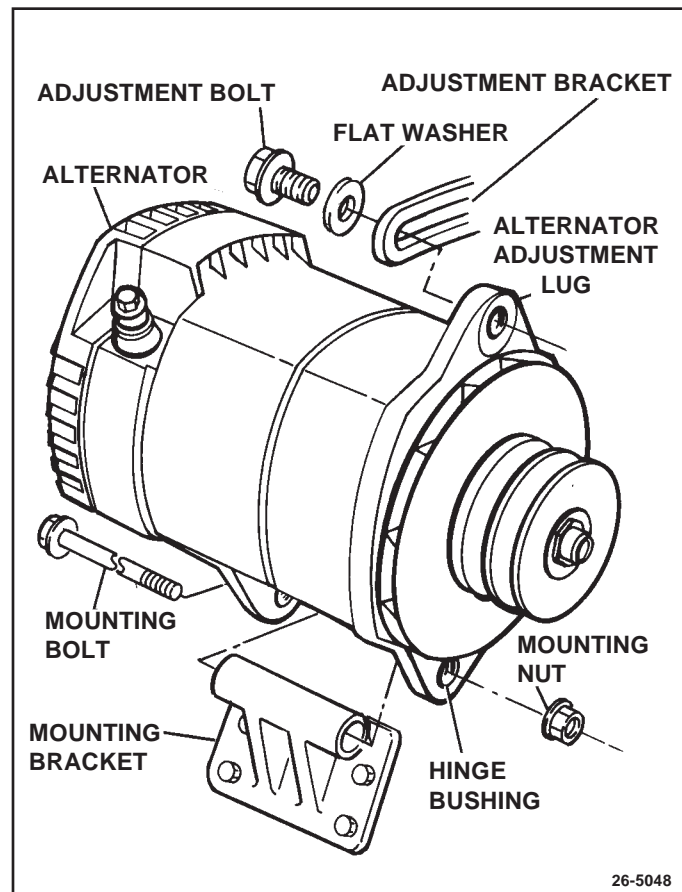

Figure 49. Installing Alternator on Engine

#### EQUIPMENT NEEDED:

- Jumper Lead (18 ga. min; no fuse)

To restore residual magnetism in alternators with an "R" or "I" terminal, alternator ground terminal must be connected to battery ground terminal. This may be done directly or through the test stand wiring. (See Fig. 48)

Disconnect carbon pile load test from battery if still connected. Disconnect any leads connected to alternator "R" or "I" terminal. Connect jumper lead under insulated battery terminal. Without touching other grounded areas (See CAUTION Above), momentarily touch ("flash") free end of jumper lead to alternator "R" or "I" terminal. The momentary current flow into the terminal will restore the proper magnetism in the rotor. Disconnect the jumper lead from the battery, then return to Step 1 and repeat Alternator Bench Test.

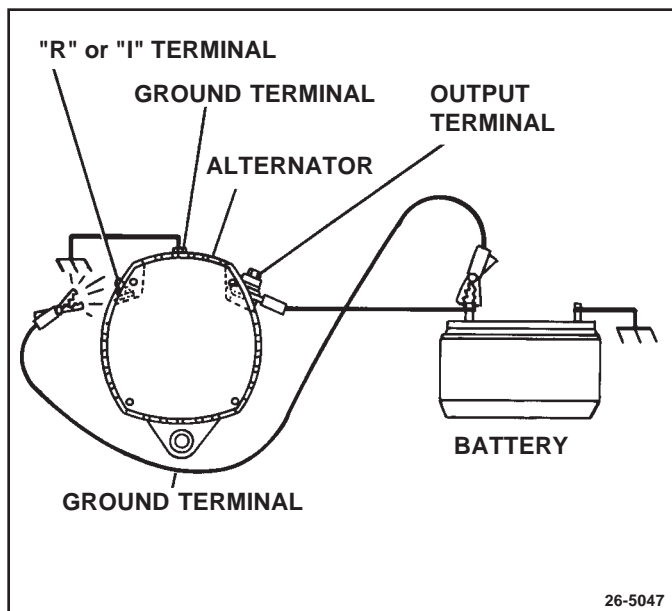

Figure 48. Restoring Residual Magnetism

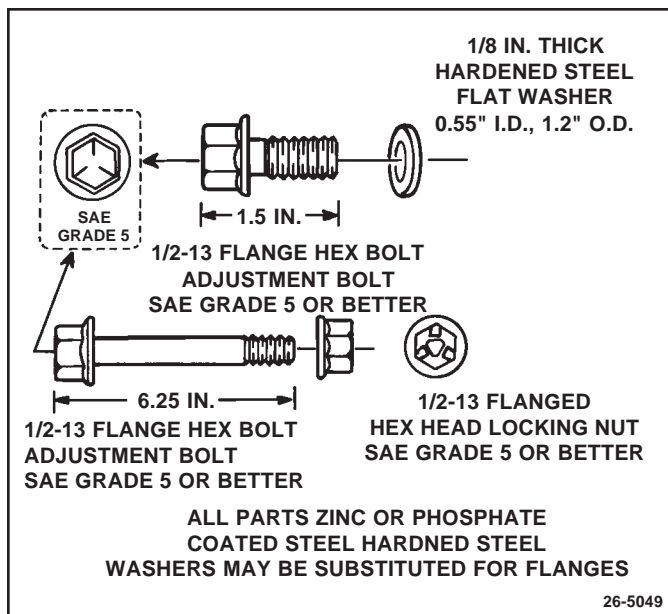

Figure 50. Alternator Mounting Bolts

### ALTERNATOR MOUNTING

**CAUTION:** Failure to disconnect grounded battery cable at battery before removing or attaching alternator "BAT" terminal lead may result in an injury. If a tool is shorted to the battery cable connector at the output terminal, the tool can quickly heat enough to cause a skin burn or to damage the tool or cable.

**NOTICE:** Always reinstall fasteners at original location. If necessary to replace fasteners, use only correct part number or equivalent.

- If correct part number is not available, use only equal size and strength.
- Fasteners that are NOT to be reused will be noted in procedure.
- Fasteners requiring thread locking compound will be noted in procedure.
- Use specified torque values when shown.

Using or replacing fasteners in any other manner could result in part or system damage.

Always follow engine manufacturer's instructions for mounting alternator on engine. The following procedure is typical and may not match all steps necessary for a particular application.

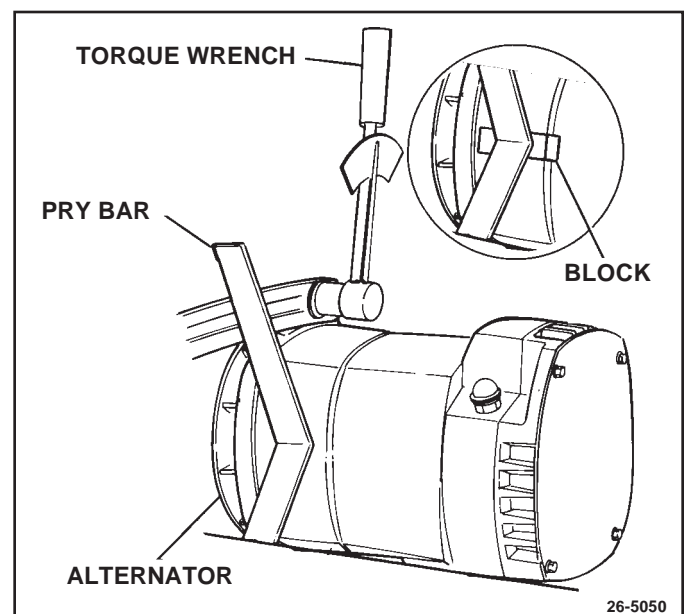

Figure 51. Adjusting Belt Tension

### TEST EQUIPMENT NEEDED:

- Belt Tension Gage

**↔ REMOVE OR DISCONNECT**

1. Negative cable at battery.

**🔧 ADJUST**

2. Mounting hinge bushing position so that the mounting lugs will fit over the bracket spool.

**→← INSTALL OR CONNECT**

3. Alternator double mounting lugs to mounting bracket on engine. (See Fig. 49) Adjust hinge bushing in mounting lug by pressing endways until it just clears the spool on the mounting bracket. Install flanged mounting bolt and flanged mounting bolt nut. If bolt and/or nut are not flanged, 1/8" thick hardened steel washers (part no. 1967343) must be substituted for flanges. (See Fig. 50)
4. Alternator adjustment lug to adjustment bracket on engine, with 1/8" thick hardened steel washer (part no. 1967343) and flanged adjustment bolt. (See Fig. 49) Finger tighten.

5. Alternator belt to pulley.
6. If engine uses automatic belt tensioner (idler), skip to Step 7.

**NOTICE:** Do not pry directly against rectifier end housing to adjust belt tension. Force must be applied to DE frame as described. Prying only against rectifier end housing may damage alternator.

If belt tension is adjusted by forcing alternator against belt, use suitable pry bar positioned against DE frame of alternator. (See Fig. 51) If DE frame is not accessible, place wood block along side of alternator against both DE frame and rectifier end housing and pry against wood block.



**ADJUST**

Using gage, adjust belt tension to engine manufacturer's specification and hold.



**TIGHTEN**

7. Adjusting lug bolt to 88 N.m (65 lb. ft.).

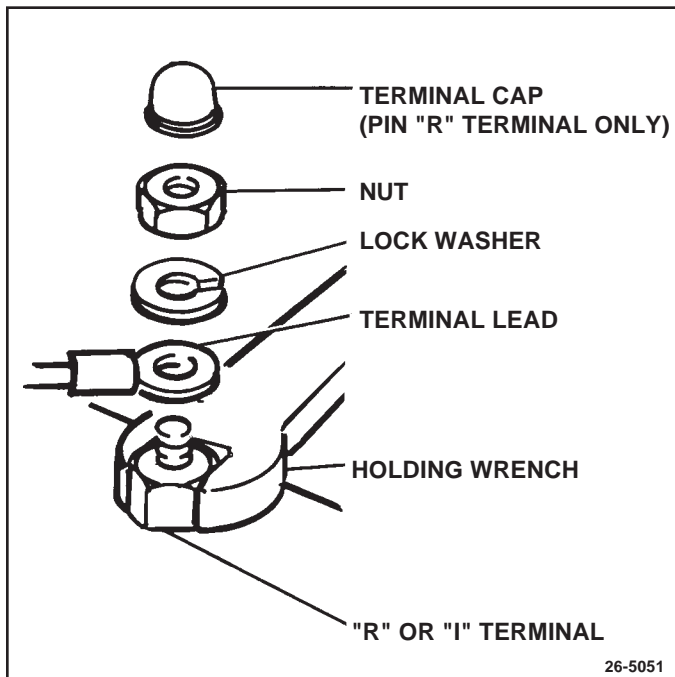

Figure 52. Threaded "I" or Pin "R" Terminal

8. Hex mounting bolt nut to 88 N.m (65 lb. ft.).



**MEASURE**

9. Use gage to recheck belt tension to be sure specification was maintained. If not, repeat tensioning procedure.



**INSTALL OR CONNECT**

10. "I" or "R" terminal connector, if used. For threaded terminals with a hex base, hold hex portion of terminal as anti-turn while tightening nut. (See Fig. 52) For post-type terminals, use 1969007 Relay Cable or equivalent. If terminal is not used in application, place insulating cap on terminal.



**TIGHTEN**

10-24 "I" or "R" terminal nut (if used) to 2.0 N.m (20 lb. in.).

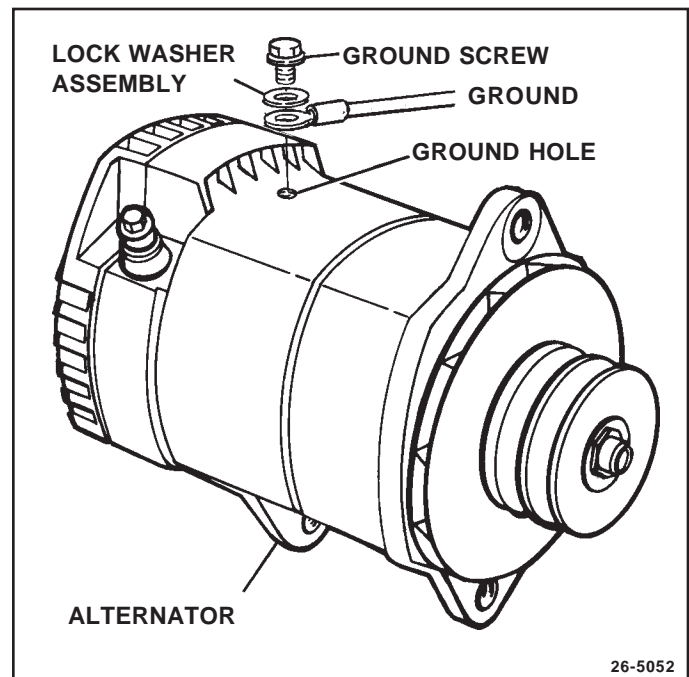

Figure 53. Installing Ground Lead

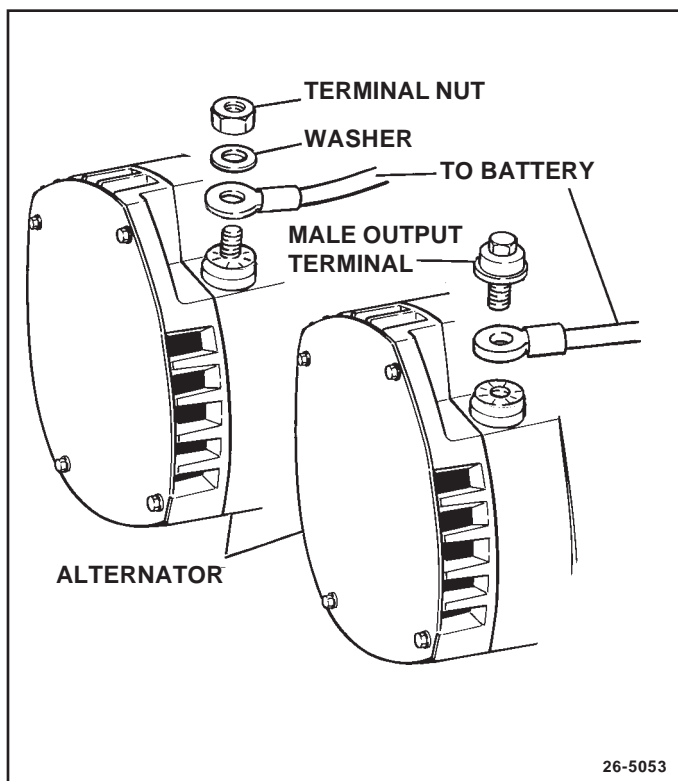

Figure 54. Connecting to Output Terminal

**→← INSTALL OR CONNECT**

11. Ground lead, if used, to ground hole in rectifier end housing, with ground screw/lockwasher assembly. (See Fig. 53) If ground lead is not used, be sure screw/lockwasher is installed in ground hole and properly tightened to prevent entry of water or dirt.

**⌚ TIGHTEN**

1/4" ground screw to 6 N.m (55 lb. in.).

**→← INSTALL OR CONNECT**

12. Battery cable to output terminal, using insulated output terminal bolt or lock washer and output terminal nut as applicable. (See Fig. 54) For insulated type, use

1971105 Chargelead Cable or equivalent and match ridges in cable contact with grooves on alternator terminal to provide anti-turn during installation.

**⌚ TIGHTEN**

Insulated output terminal bolt to 14 N.m (120 lb. in.), or 1/4" output terminal nut to 7 N.m (65 lb. in.).

13. Connect negative cable at battery.

**26-SI ALTERNATOR SPECIFICATION**

The typical 26-SI Alternator rotor field check at 12-volts is 3.0 - 4.3 current amps and 2.8 - 4.0 ohms @ 80° F. The rotor field check at 24 volts is 2.0 - 2.8 current amps and 8.5 - 12.0 ohms at 80° F.

Cold Current output at 80° F is shown in the following table.

Alternator Model	Amperes @ 80° F	
	1800 rpm	5000 rpm
12V/85A	56	85
24V/50A	33	50
24V/75A	45	75

For further information on rotations and exact specification number on these or other Delco Remy Products: Call 1-800-DRA-0222

## SERVICE PARTS

Illus. No.	Name	Qty.	Illus. No.	Name	Qty.
1.	Housing, Rectifier End	1	32.	Screw/Lockwasher, Rect. Covr. Atch. (3/4")	3
2.	Bearing, Rectifier End Outer Race	1	33.	Screw/Lockwasher, Rect. Covr. Atch. (1 3/8")	4
3.	Bearing, Rectifier End Inner Race	1	34.	Screw/Lockwasher, Rect. End Plate Atch.	4
4.	Rotor Assembly	1	35.	Screw/Lockwasher, Regulator Atch. (Ground)	1
5.	Stator Assembly	1	36.	Screw/Lockwasher, Regulator Atch. (Insul.)	2
6.	Frame, Drive End (DE)	1	37.	Screw/Lockwasher, Mounting Plate Atch.	1
7.	Bearing, DE	1	38.	Screw/Lockwshr, Diode Trio Assembly Atch.	1
8.	Field Coil and Support	1	39.	Washer, Diode Heat Sink Attachment Screw	4
9.	Regulator	1	40.	Washer, Diode Trio Assembly Attachment	1
10.	Diode, In Frame	3	41.	Washer, now included with #37	1
11.	Diode, Heat Sink	3	42.	Washer, Shaft Nut	1
12.	Heat Sink	1	43.	Bolt, Thru	4
13.	Stud Package, Diode Junction	3	44.	Bushing, Mounting Hinge (Rect. Hsg.)	1
14.	Heat Sink Assembly	1	45.	Cap, Relay Terminal Insulating	1
15.	Diode Trio Assembly	1	46.	Clip, Terminal (Stator Leads)	3
16.	Terminal, Output (Male)	1	47.	Gasket, Rectifier End Cover	1
17.	Terminal Pkg., Output (Female)	1	48.	Grommet, Stator Leads	1
18.	Terminal Pkg., "R" or "I"	1	49.	Grommet, Field Coil Assembly	1
19.	Cover, Rectifier End	1	50.	Insulation, Diode Heat Sink to Rect. Hsg.	1
20.	Plate, Rectifier End	1	51.	Insulator, Diode Heat Sink Atch. Screw	4
21.	Retainer Plate, DE	1	52.	Insulator, Stator Lead Grommet	1
22.	Collar, DE (Inside)	1	53.	Lead, Regulator Stud to Diode Heat Sink	1
23.	Fan	1	54.	Plate, Regulator Mounting	1
24.	Lock Washer, Ground Screw	1	55.	Plug, Expansion (Rectifier Housing)	1
25.	Nut, Diode Trio to Stator Lead Attachment	3	56.	Plug, Pipe (Rectifier Housing)	1
26.	Nut, Regulator Stud	1	57.	Support, Regulator Lead	1
27.	Nut, Shaft	1			
28.	Screw, DE Bearing Retainer Attachment	4		Miscellaneous (not shown):	
29.	Screw, Field Coil and Support Attachment	3		Capacitor, Radio Suppression	
30.	Screw, Ground	1		Lead Assembly, Indicator Light	
31.	Screw/Lockwasher, Diode Heat Sink Atch.	4			

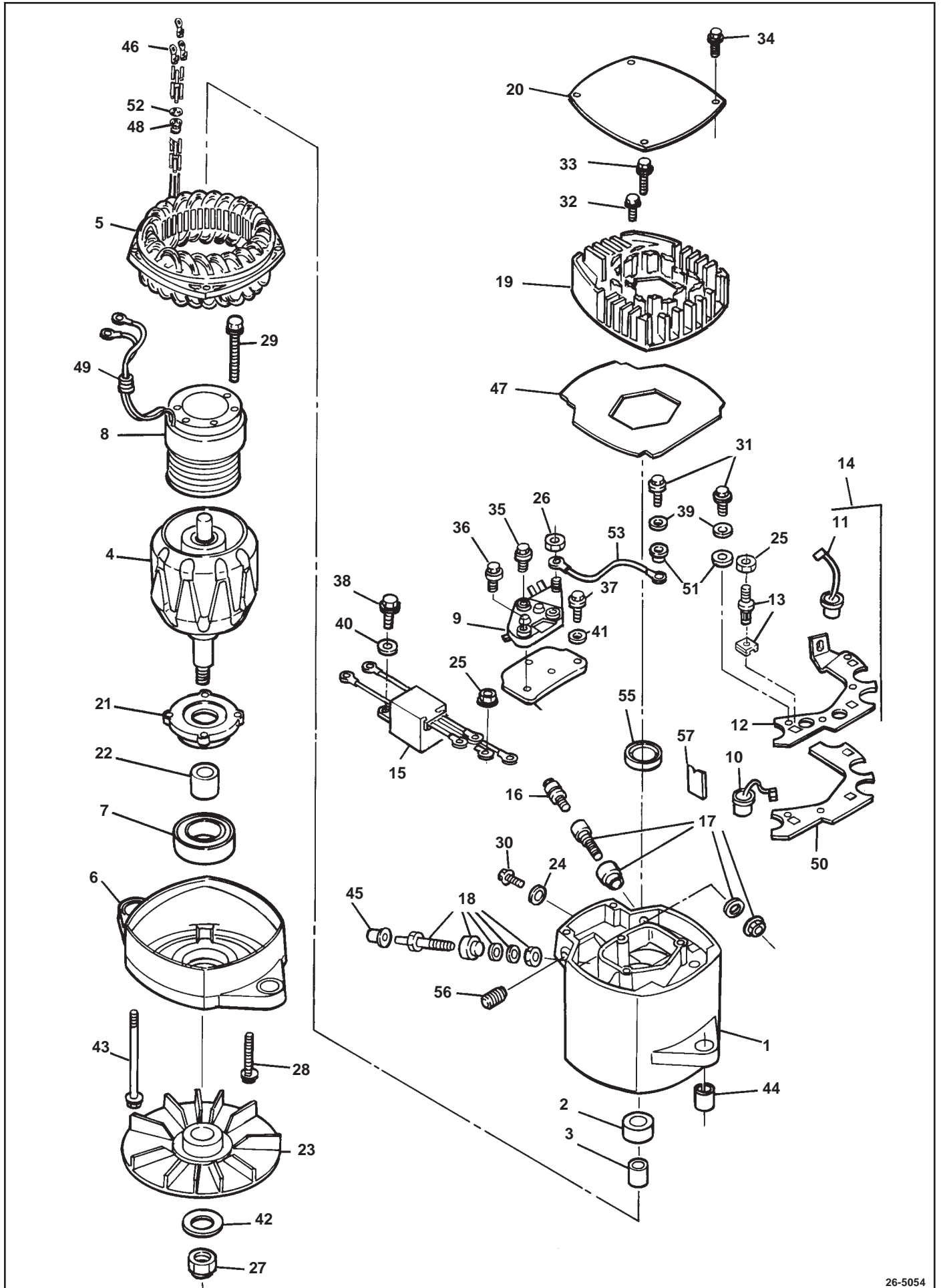



**Delco Remy International, Inc.**  
2902 Enterprise Drive  
Anderson, IN 46013

**For further information and specifications on these and other  
Delco Remy Products call: 1-800-DRA-0222**